

## Drill Press Table Plans



A drill press table is indispensable for the serious wood craftsman. The work table on most drill presses is usually small and has holes for mounting the traditional drill press vice. That works OK for holding small pieces of metal, but it's not suitable for woodworking.

For working with wood, we need a larger work surface and a more versatile way to clamp the work piece. This table, by use of T-Track, hold down clamps, and toggle clamps permits accurate clamping and positioning of the work piece. The fence makes drilling repetitive holes easy. An added benefit is that this one is extremely easy to mount. Simply slide it onto your drill press table and tighten the two knobs. It's simple, easy to make and quite inexpensive.

# Table of Contents

Please read and follow all tool manufacturers safety and operating instructions before operating equipment. Always wear eye and hearing protection.

Materials List .....	1
Drill Press Table Parts – (A) .....	2
Drill Press Table Parts – (B) .....	3
Drill Press Table Parts – (C) .....	4
Assemble the Top .....	5
Assemble the EZ-Mount Clamps .....	6
Assemble the Fence .....	7
Full Patterns .....	8

## Introduction

Thank you for visiting BobsPlans.com. I hope you find this drill press table to be a rewarding and useful project. The top has a base made of 3/4" MDF board. The base is covered with eight pieces of 1/2" plywood and five sections of T-Track.

This makes it easy to include the T-Track without having to cut slots in a solid top. Plus, it allows for the middle section of plywood to be easily replaced after it becomes worn. The two sections to the right and left of the replaceable section have notches to facilitate removal of the center section. Since the individual pieces are fairly small, you may very well have enough scrap material around to make this project.

This project includes two easy to make clamps that make it quick and easy to mount and remove the drill press table. They work like built in C-clamps. The risers should be the same height as the thickness of the steel table that is built in to your drill press. You simply slide the table in place and tighten the two knobs. The rear sides are cut to provide access to the table positioning crank. (Not all drill presses have a crank, but for those that do, this provides access.)

The plans include a simple but versatile fence that is designed to be locked in place by T-Track bolts. The dimensions of the top sections are such that the two outer T-Track strips will have ten inches between centers. The fence base has two 5/16" holes that are ten inches between centers so they align with the T-Track.

Sources for the T-Track and clamps you'll need are provided on the sponsor's page.

## Pro's Choices - Woodworking Tools & Accessories

Note: Images and underlined blue text are active web links.



[Kreg® K3 Pocket Hole Jig](#)



[Large Plate Router Table](#)



[Saw Blade Tool](#)

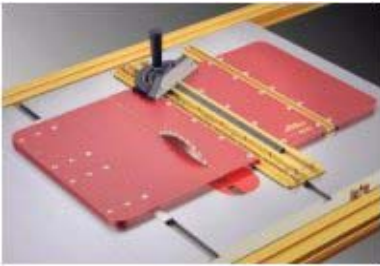

[Inkra® Miter Sled](#)



[Leigh® Dovetail Jig](#)



[Avenger Dado Set](#)



[Inkra® Miter Gauge](#)



[Drill Doctor®](#)



[Clamping Miter Gauge](#)



[Clamp Clip](#)



[Brad Nailer](#)



[Rotary Shaper](#)



[Tenon Cutters](#)



[Self Centering Bits](#)



[Roller Stand](#)



[Tormek® Sharpening](#)

## Pro's Choices - Drill Press Tables & Accessories

Note: Images and underlined blue text are active web links.



[Drill Press Table & Fence](#)



[Drill Doctor® Bit Sharpener](#)



[Mini Drill Press Table & Fence](#)



[Portable Drill Guide](#)

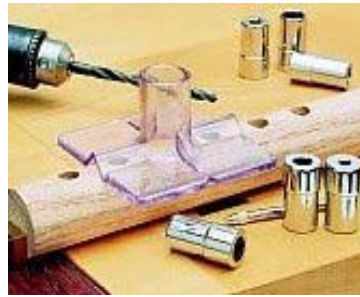

[Self Centering Drill Guide](#)



[Jet® Mortising Tool](#)



[Forstner Bits](#)



[Self Centering Bits](#)



[Tenon/Plug Cutters](#)



[Rotary Shaper](#)



[Hold Down Clamp Kit](#)

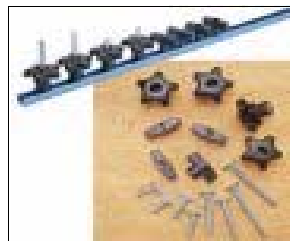

[T-Track & Hardware Kit](#)

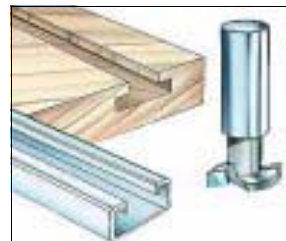

[T-Slot Cutter](#)



[Toggle Clamps](#)

# Materials List

Page 1

## Drill Press Table Materials List

Qty	Item Name	Size	Material
1	Top	18" X 12	3/4" MDF
2	Clamp Blocks	5" X 3" X 3/4"	3/4" Stock
2	Clamp Risers	3" X 1 1/2" X 1"	1 1/2 Stock
2	Top Section - A	3 1/2" X 5"	1/2" Plywood
2	Top Section - B	1 1/4" X 5"	1/2" Plywood
2	Top Section - C	5 1/2" X 3 1/2"	1/2" Plywood
2	Top Section - D	6 1/4" X 4"	1/2" Plywood
1	Top Section - E	5 1/2" X 5 1/2"	1/2" Plywood
1	Top Section - F	18" X 2 1/4"	1/2" Plywood
1	Fence	18" X 3"	1/2" Plywood
1	Fence Base	12" X 4"	1/2" Plywood
2	Fence Gusset	3" X 2"	3/4" Stock
4	T-Track	5"	Aluminum T-Track
1	T-Track	18"	Aluminum T-Track
2	Dowel Pins	1/4" X 1/2"	N/A
2	Knobs	5/16" threads	N/A
2	Hold Down Clamps	N/A	N/A
2	Carriage Bolts	5/16" X 3 1/2"	N/A

# Drill Press Table Parts - (A)

Page 2

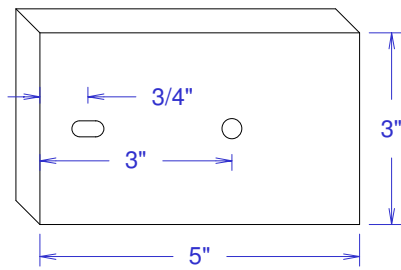
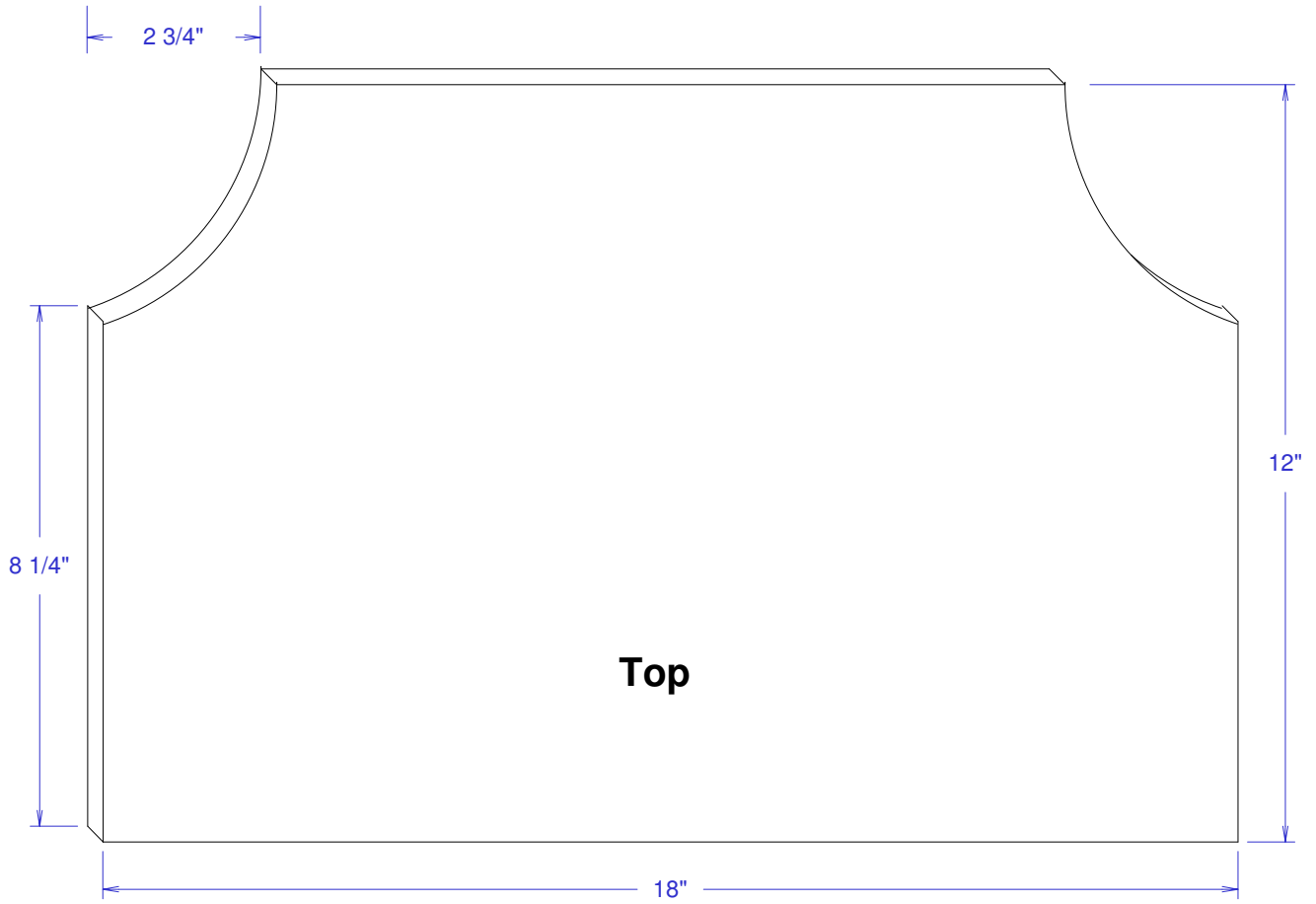

**Clamp Blocks**

(2 Required)

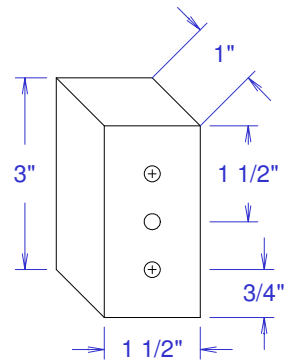

**Clamp Risers**

(2 Required)

# Drill Press Table Parts - (B)

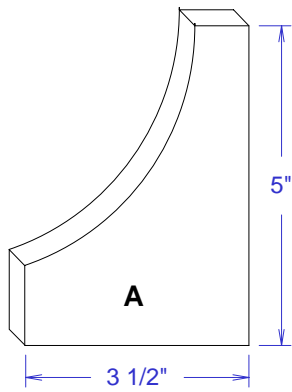

**Top Section A**  
(2 Required)

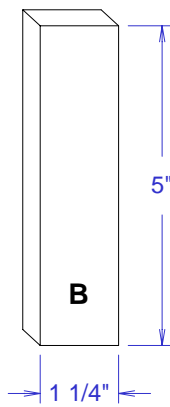

**Top Section B**  
(2 Required)

All of the pieces are made from  
1/2" stock.

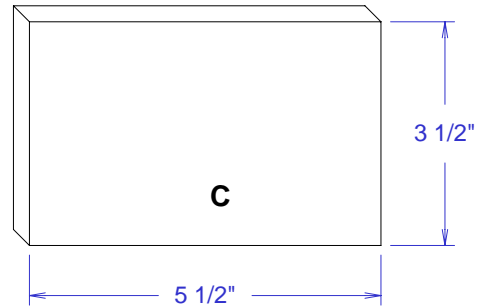

**Top Section C**  
(1 Required)

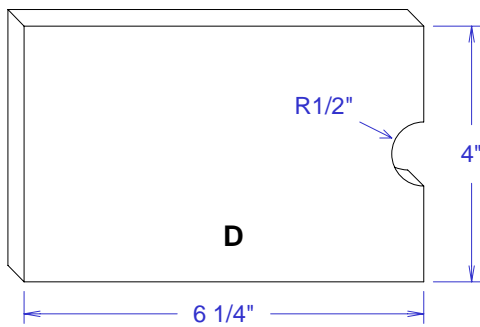

**Top Section D**  
(2 Required)

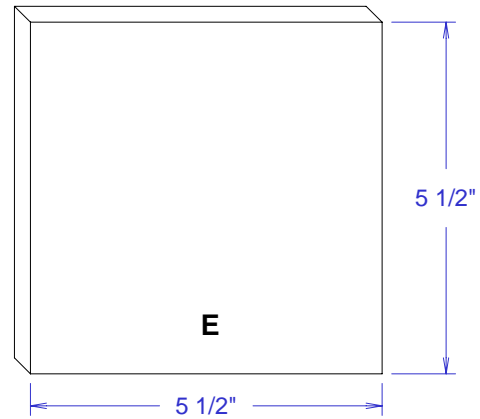

**Top Section E**  
(1 Required)

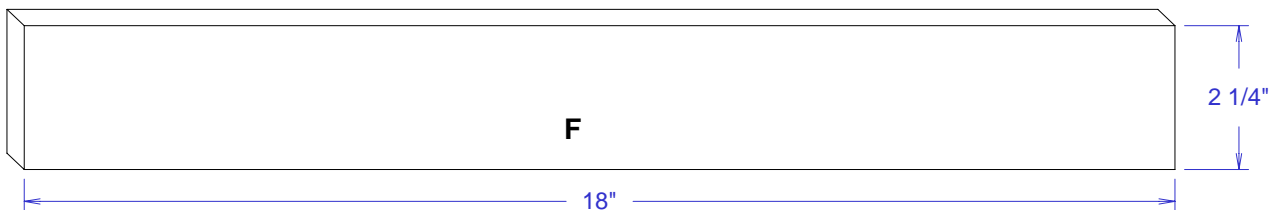

**Top Section F**  
(1 Required)

# Drill Press Table Fence Parts - (C)

The two notches are for drill press chuck and handle clearance.

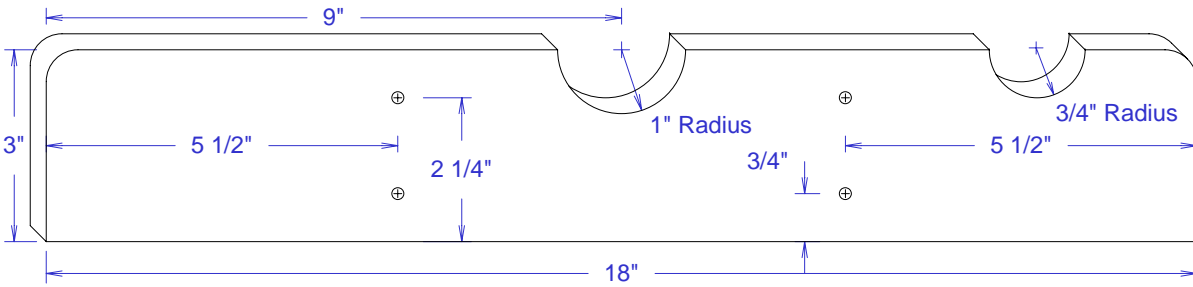

## Fence

The notch is for drill press cloumn clearance.

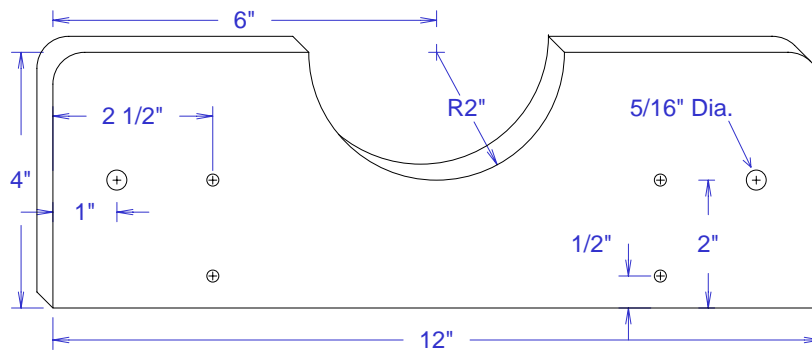

## Fence Base

Fence & Fence Base are made from 1/2" stock.

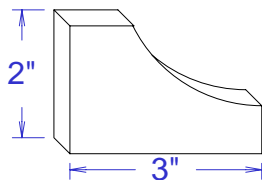

## Gusset

(2 Required)

The fence and fence base each have four holes for #8 screws for attaching the gussets. On the fence, these should be countersunk on the front. They should be countersunk on the underside of the base. The base also has two 5/16" diameter holes for the T-Track bolts.

Gussets are made from 3/4" stock.

# Drill Press Table Assembly - (A)

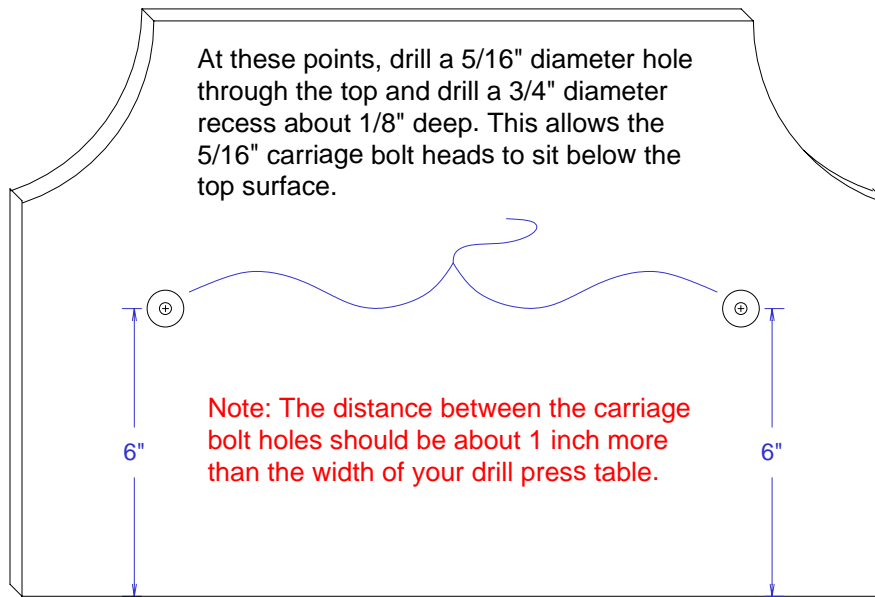

Drill the holes for the EZ-Mount clamp carriage bolts.

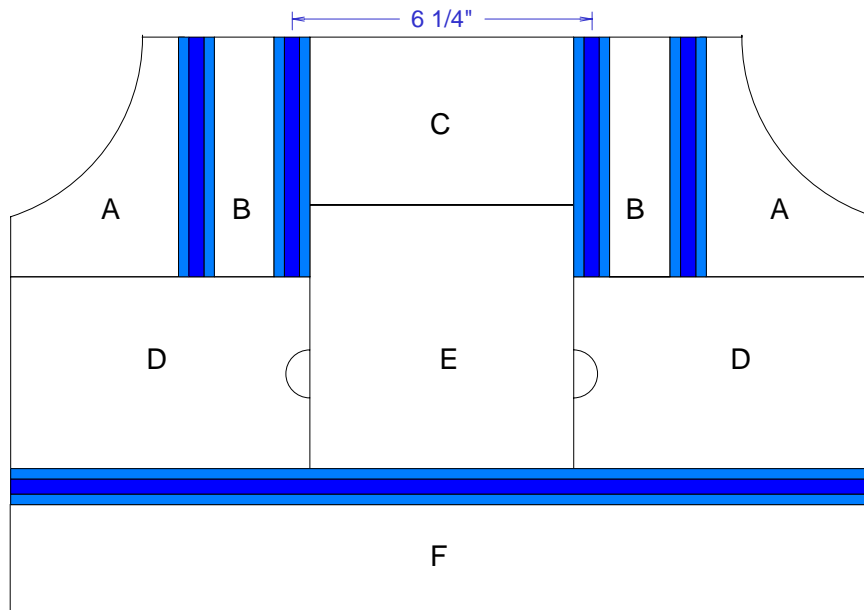

Insert the carriage bolts through the top and attach the top sections with screws or finishing nails. (Don't attach the center section. Leave it loose so you can replace it when it becomes worn.) Attach the T-Track with flathead screws.

# Drill Press Table Assembly - (B)

Page 6

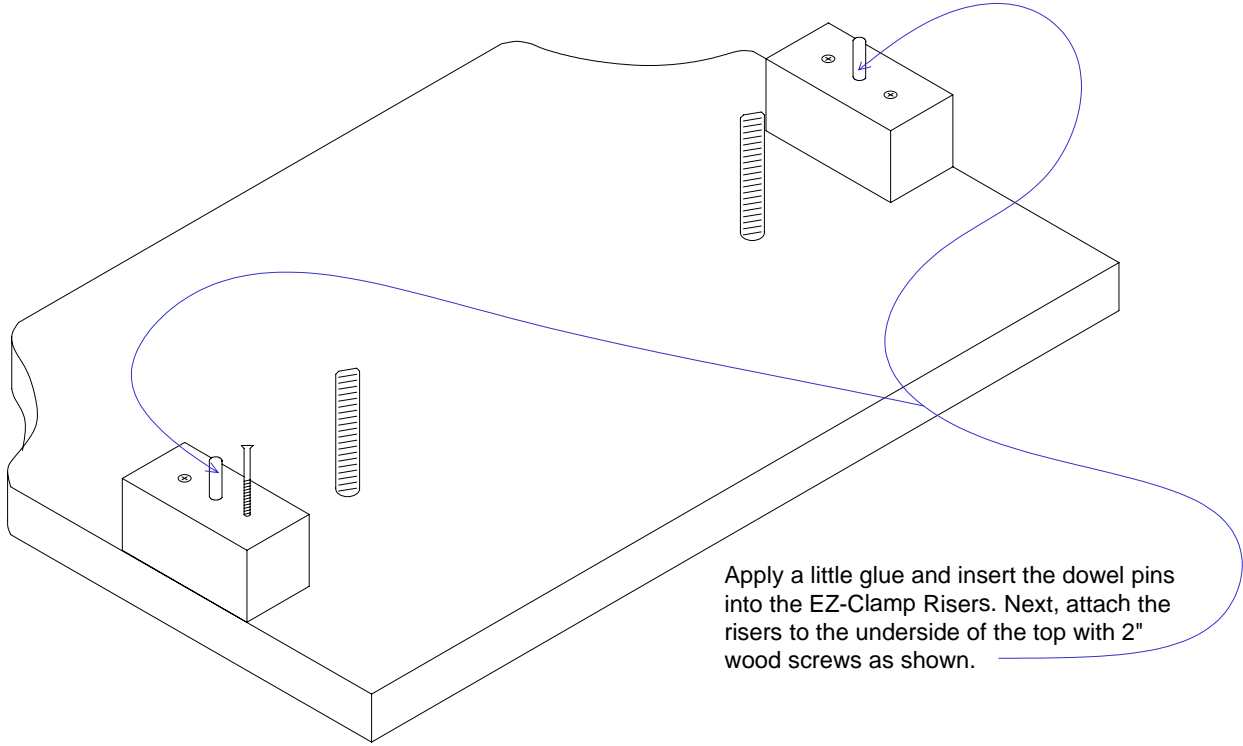

Apply a little glue and insert the dowel pins into the EZ-Clamp Risers. Next, attach the risers to the underside of the top with 2" wood screws as shown.

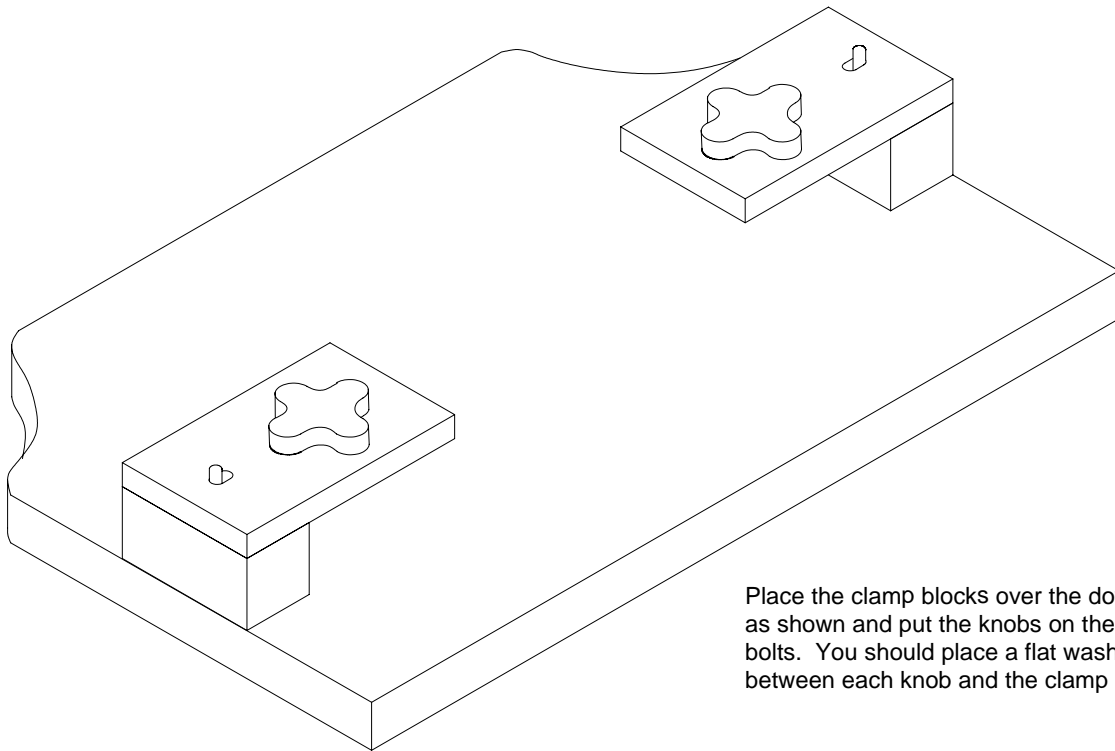

Place the clamp blocks over the dowel pins as shown and put the knobs on the carriage bolts. You should place a flat washer between each knob and the clamp blocks.

# Drill Press Table Assembly - (C)

Page 7

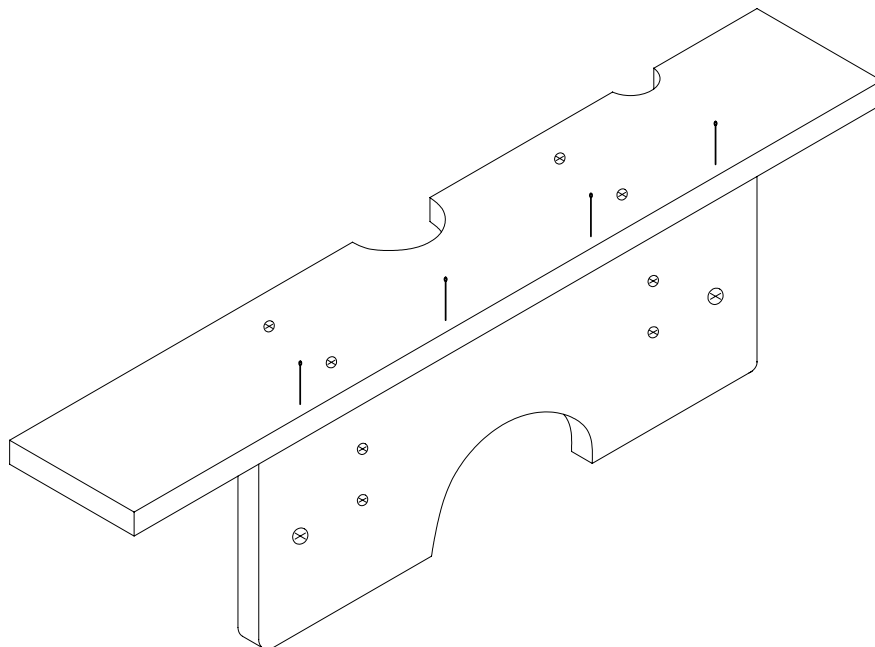

Apply some glue and attach the base to the fence with 1" finishing nails.

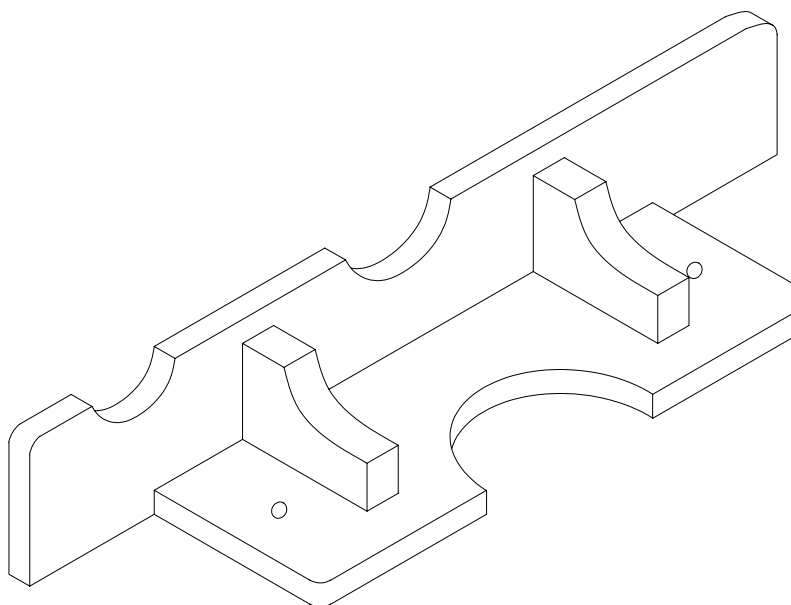

Apply some glue and attach the gussets to the base and the fence with 1 inch #8 woodscrews. Your drill press table and fence are now finished and ready to use.

Full Size Patterns

