



www.BobsPlans.com

Heartwheel Wheelbarrow

Plans & Instructions



This durable wheelbarrow planter makes a beautiful addition to any landscape. It's easy to build and when constructed from cedar, cypress, redwood, or other decay resistant wood, will last for decades.

Full size templates are included for all non-straight cuts.

Copyright © 2005 by Robert E. Reedy
All rights reserved

Table of Contents

Leg Drawings	1
Frame Parts Drawings	2
Handle Patterns	3
Assembling the Frame.....	4
Wheel Center Boards	5
Assembling the Center Boards	6
Heart Patterns (1)	7
Heart Patterns (2)	8
Heart Layout	9
Cutting the Heart Circle	10
Wheel Trim Patterns	11
Attaching Rim Segments	12
Attaching the Hub	13
Mounting the Wheel.....	14
Tub Assembly Instructions	15
Tub Assembly Drawings (A)	16
Tub Assembly Drawings (B)	17
Tub Assembly Patterns (A).....	18
Tub Assembly Patterns (B)	19
Tub Assembly Patterns (C)	20
Final Assembly	21
Materials List	22

Introduction

Thank you for purchasing our Heartwheel Wheelbarrow Plans. Please read these instructions before starting.

This wheelbarrow is not a working wheelbarrow. It is designed for use as a flower planter only. Please read and follow all tool manufacturers safety instructions before operating equipment. Always wear safety glasses and hearing protection.

Note:

- Coated/rust resistant deck screws should be used for assembly. I recommend using a good quality exterior glue in addition to the wood screws.
- Full size patterns are provided for scroll cuts. These patterns overlaid on a grid with each line on the grid representing 1/2".
- Because of the variation in accuracy from different printers, your printed pages may not be the exact scale. The scroll cuts for this projects are not critical and most printers should reproduce the patterns close enough to scale that you can trace directly from the patterns with no problem.
- This project may be built with basic hand tools. However, if you have a router, you may want to ease the exposed edges of the wood parts with a 1/8" or 1/4" rounding over bit as you prefer. If you do not have a router, you can smooth out the edges with sandpaper.

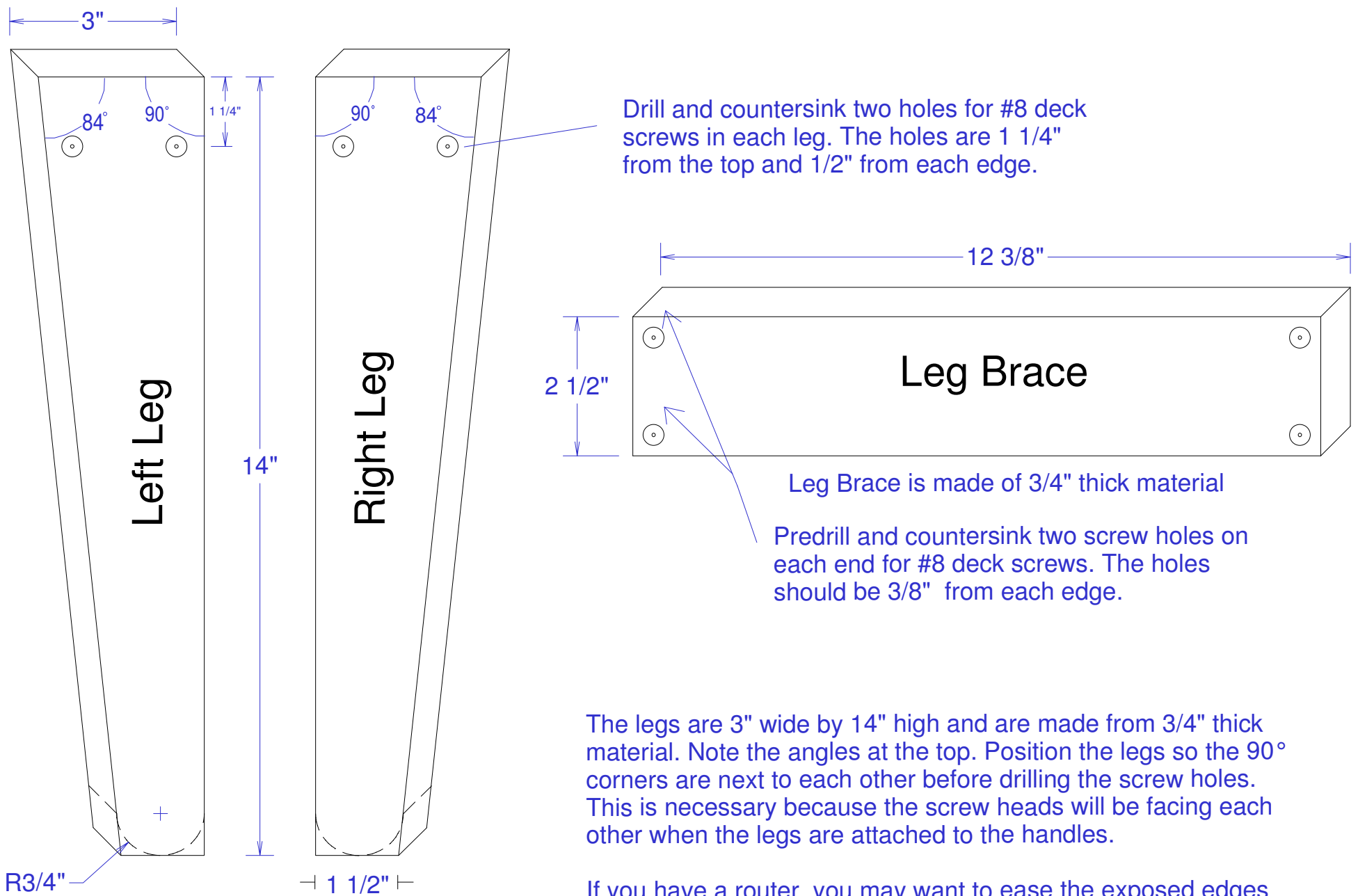

Drill and countersink two holes for #8 deck screws in each leg. The holes are 1 1/4" from the top and 1/2" from each edge.

Leg Brace is made of 3/4" thick material

Predrill and countersink two screw holes on each end for #8 deck screws. The holes should be 3/8" from each edge.

The legs are 3" wide by 14" high and are made from 3/4" thick material. Note the angles at the top. Position the legs so the 90° corners are next to each other before drilling the screw holes. This is necessary because the screw heads will be facing each other when the legs are attached to the handles.

If you have a router, you may want to ease the exposed edges with a 1/4" rounding over bit. It is not necessary to ease the top edges.

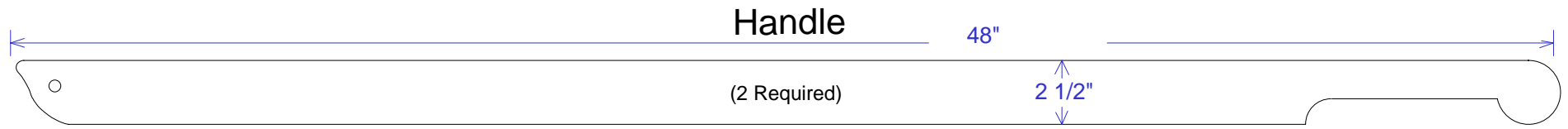

The handles are 2 1/2" wide by 48" long and are made from 3/4" thick material. Full size patterns are provided on the next page for the ends.

You can mark the location of the axle holes now but don't drill these holes until the frame is assembled. Page 3 shows how to mount a piece of scrap wood to the frame to make it easy to drill the axle holes at the correct angles.

If you have a router, you may want to ease the exposed edges of the handles with a 1/4" rounding over bit. It is not necessary to ease the edges of the cross member supports or the cross member.

Axle

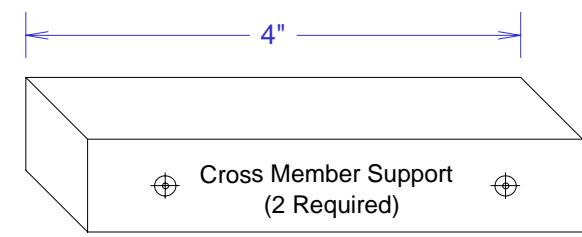
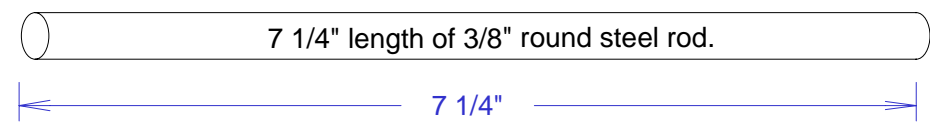

Support is 4" long by 3/4" by 3/4"

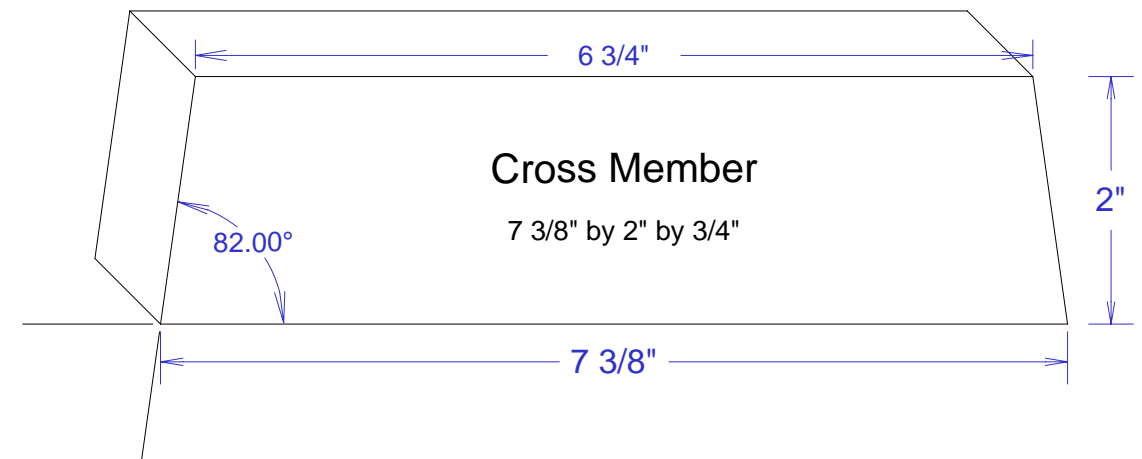

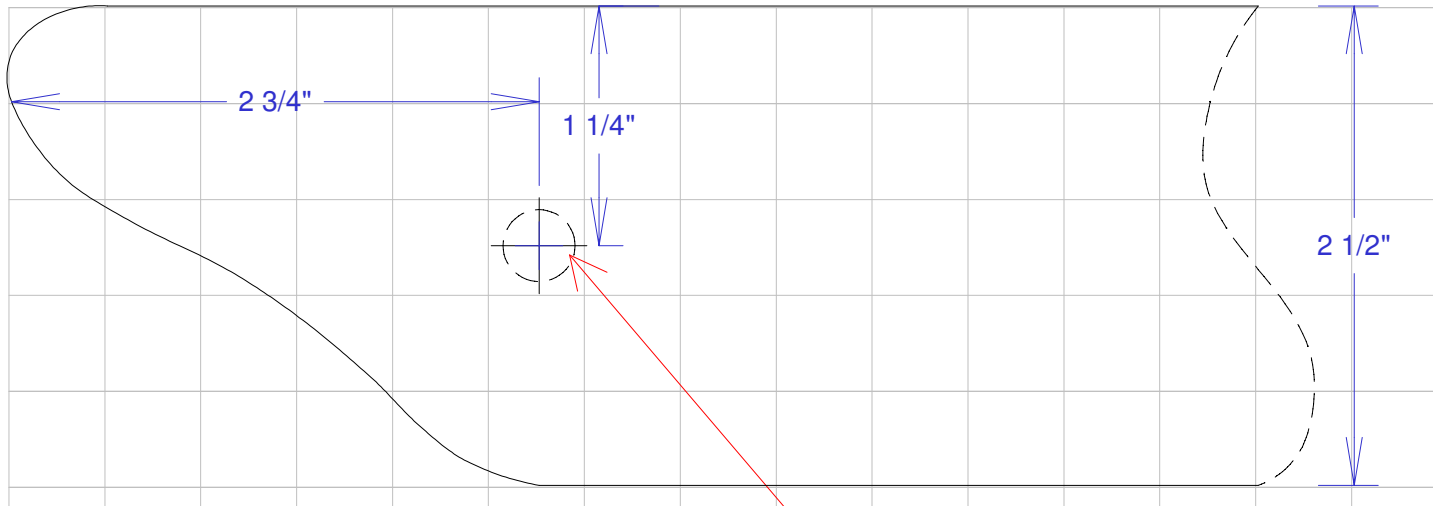

Mark the location of the axle hole but do not drill it yet. This hole must be drilled at an angle and it is much easier to do it after the frame is assembled.

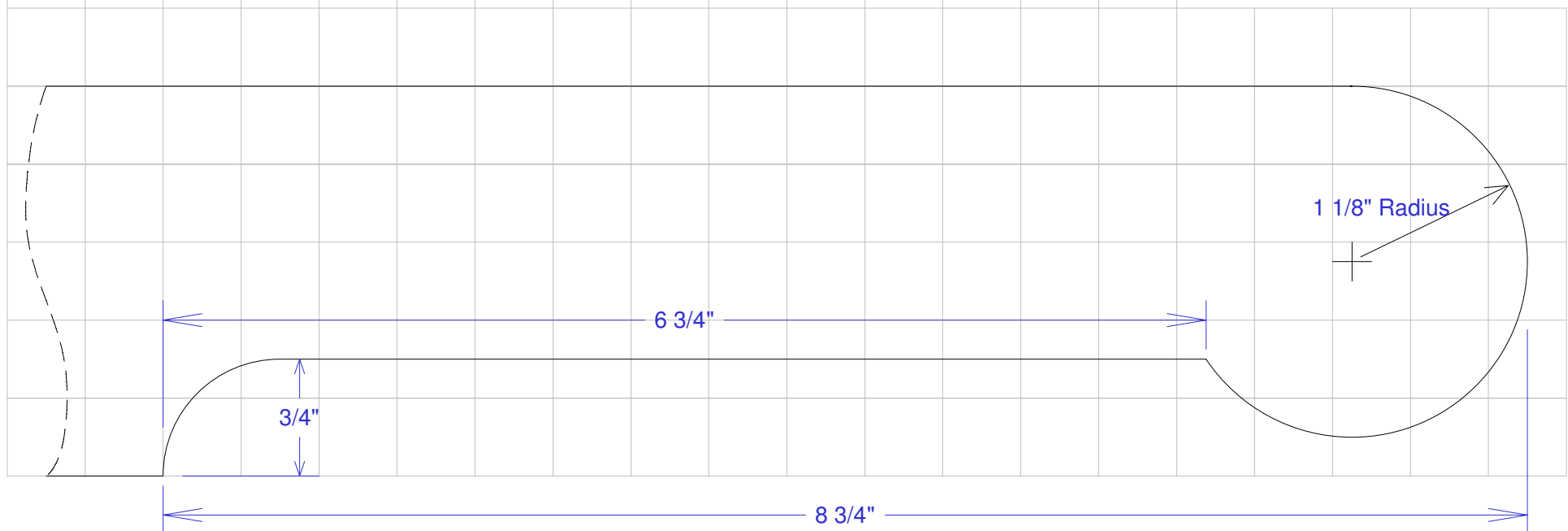

Grid lines are 1/2" apart

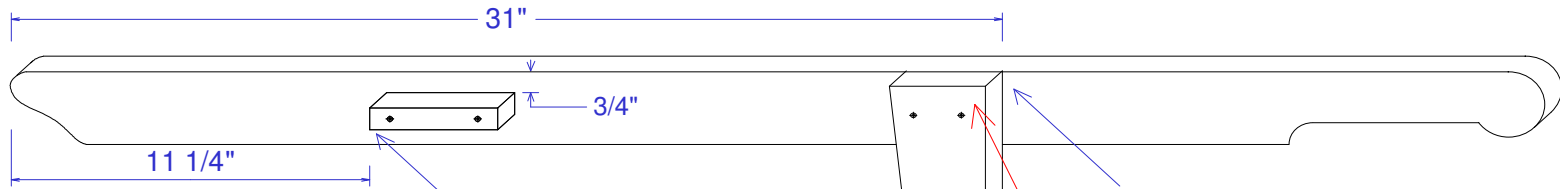

Step 1.
Mount the Crossmember Support 11 1/4" from the front end of each handle and 3/4" from the top with 1 1/4" deck screws as shown.

Step 2.
Mount the Leg to each handle 31" from the front with 1 1/4" deck screws as shown.

Note: Since the legs are tapered, each leg has only one angle on top that is 90°. This 90° angle is oriented to the rear of the handle.

Step 3.
Mount the Crossmember flush to the crossmember Support with 1 1/4" deck screws as shown.

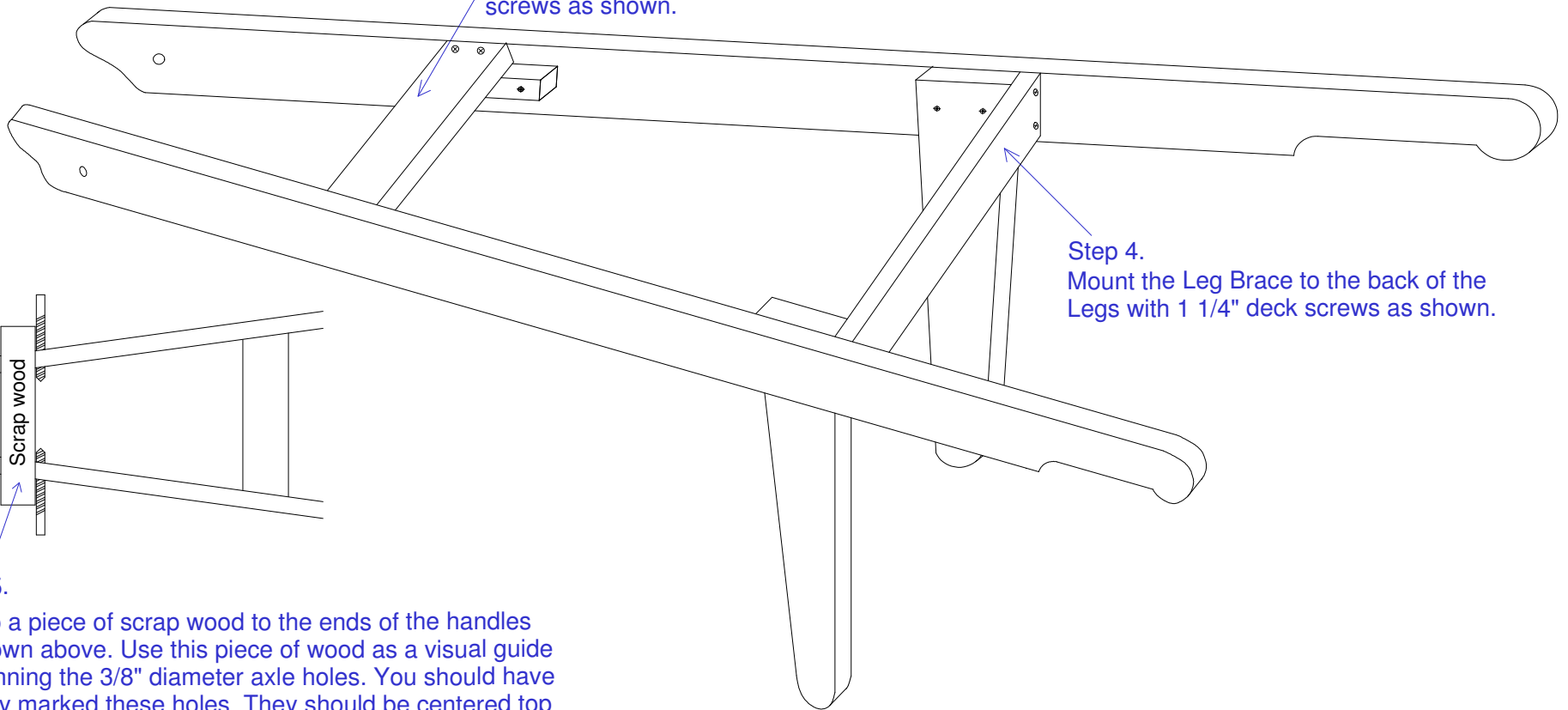

Step 4.
Mount the Leg Brace to the back of the Legs with 1 1/4" deck screws as shown.

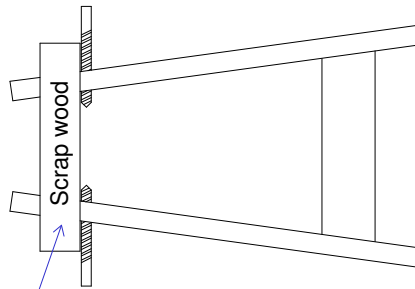

Step 5.
Clamp a piece of scrap wood to the ends of the handles as shown above. Use this piece of wood as a visual guide for drilling the 3/8" diameter axle holes. You should have already marked these holes. They should be centered top to bottom and 2 3/4" from the ends of the handles.

Making the Wheel

Cut two 7" wide by 14" long boards from 3/4" stock.
Drill one pocket hole on the left end of each board as shown.
The pocket hole should be 1" from the left edge.

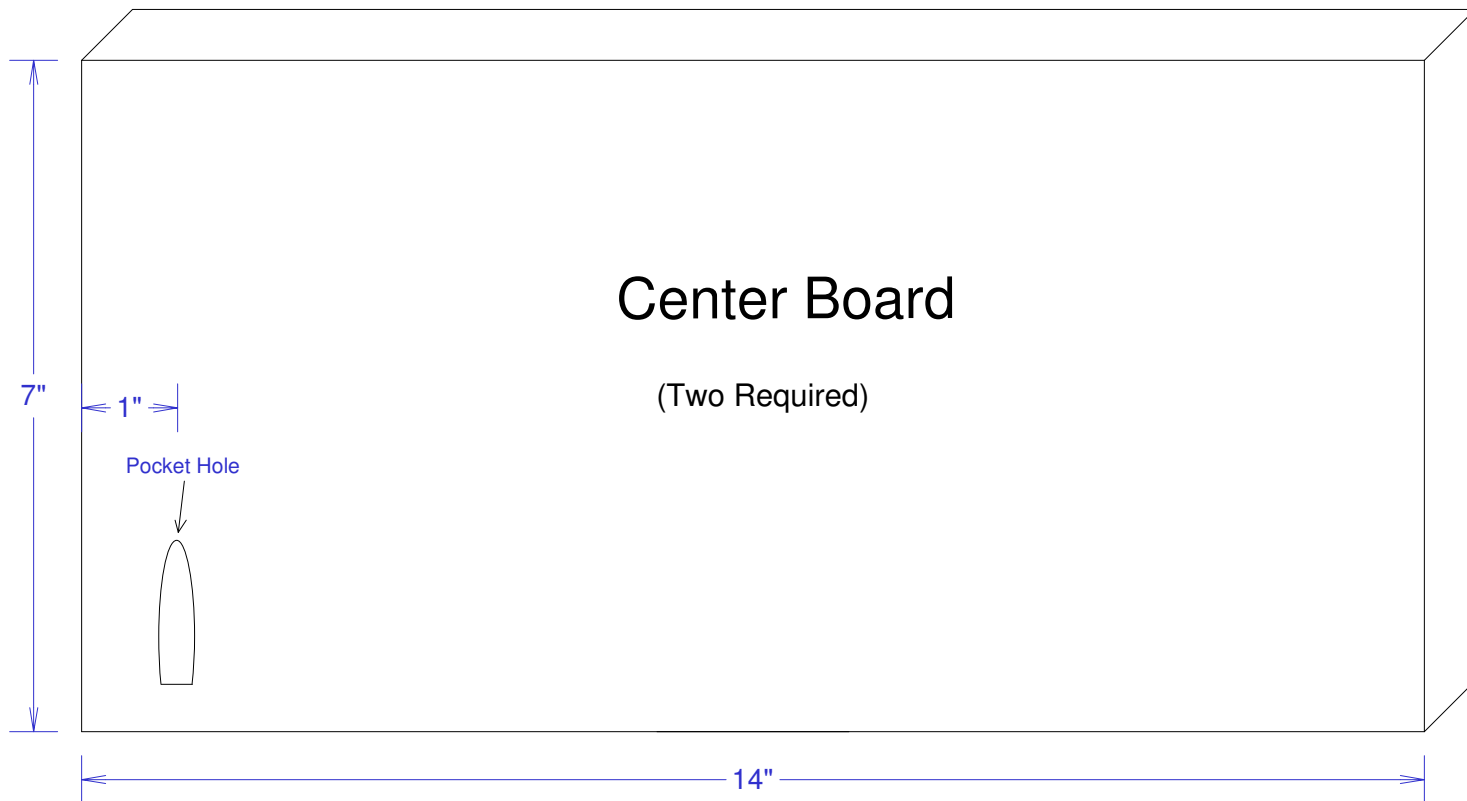

Apply weatherproof glue to the mating edges of the boards and assemble as shown. If you have a pocket hole jig, you can secure them together with pocket hole screws as shown.

Otherwise, you'll need to clamp them until the glue sets. If you don't have clamps large enough, you can stretch a couple of stretch cords around them. (The type of stretch cords with hooks you use to secure items in a truck bed.)

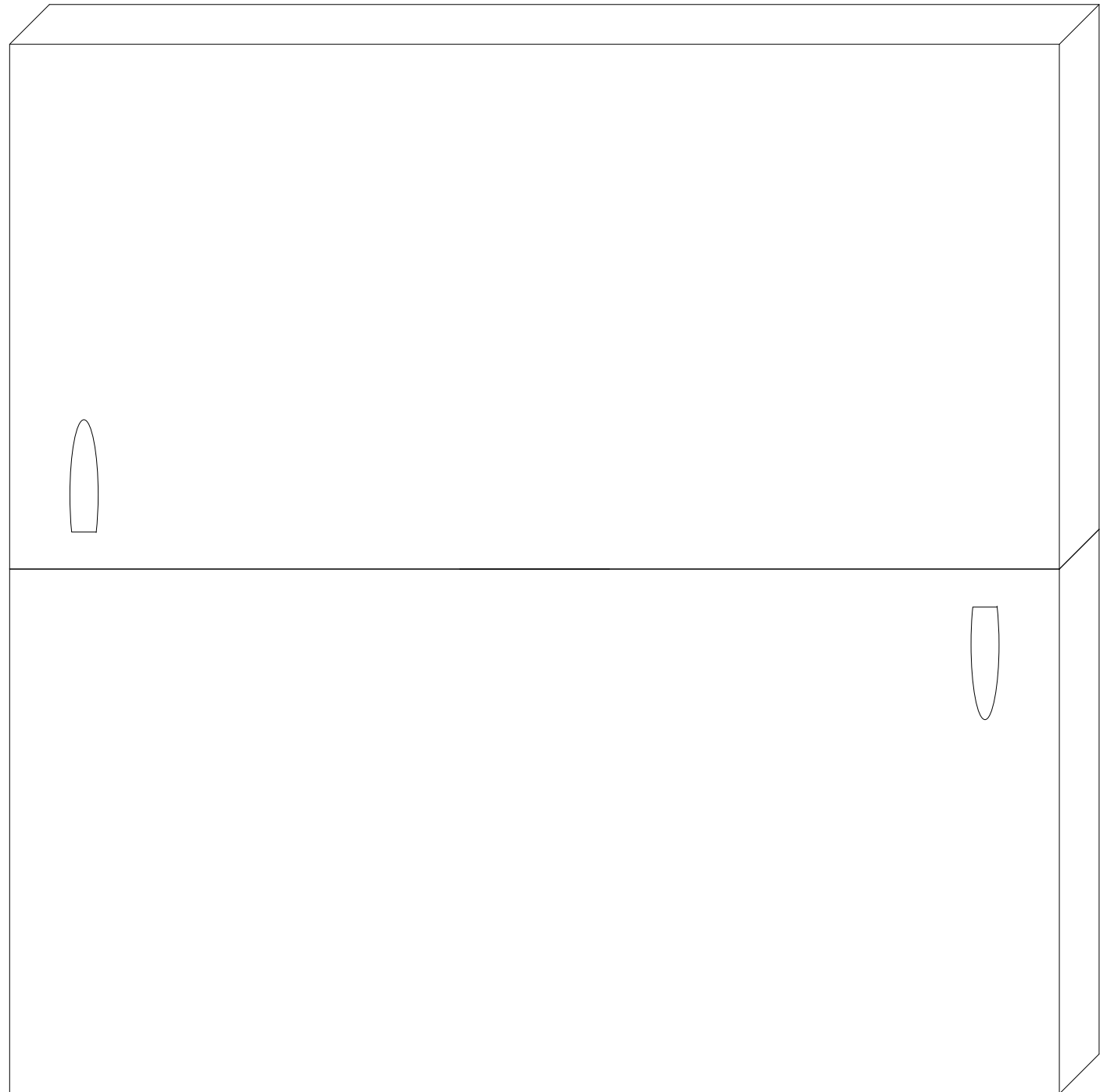

Heart Wheelbarrow - Assemble Center Boards

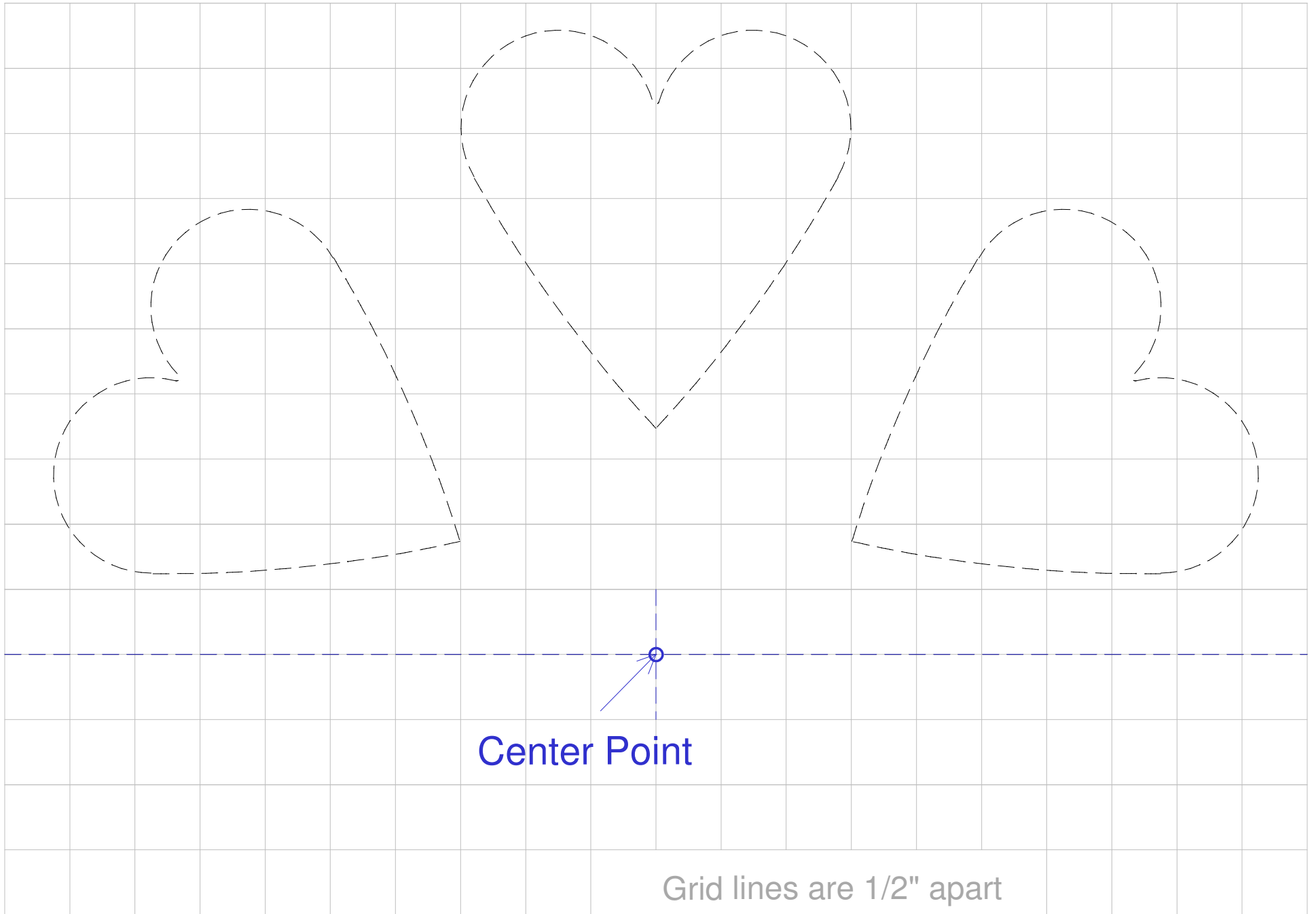

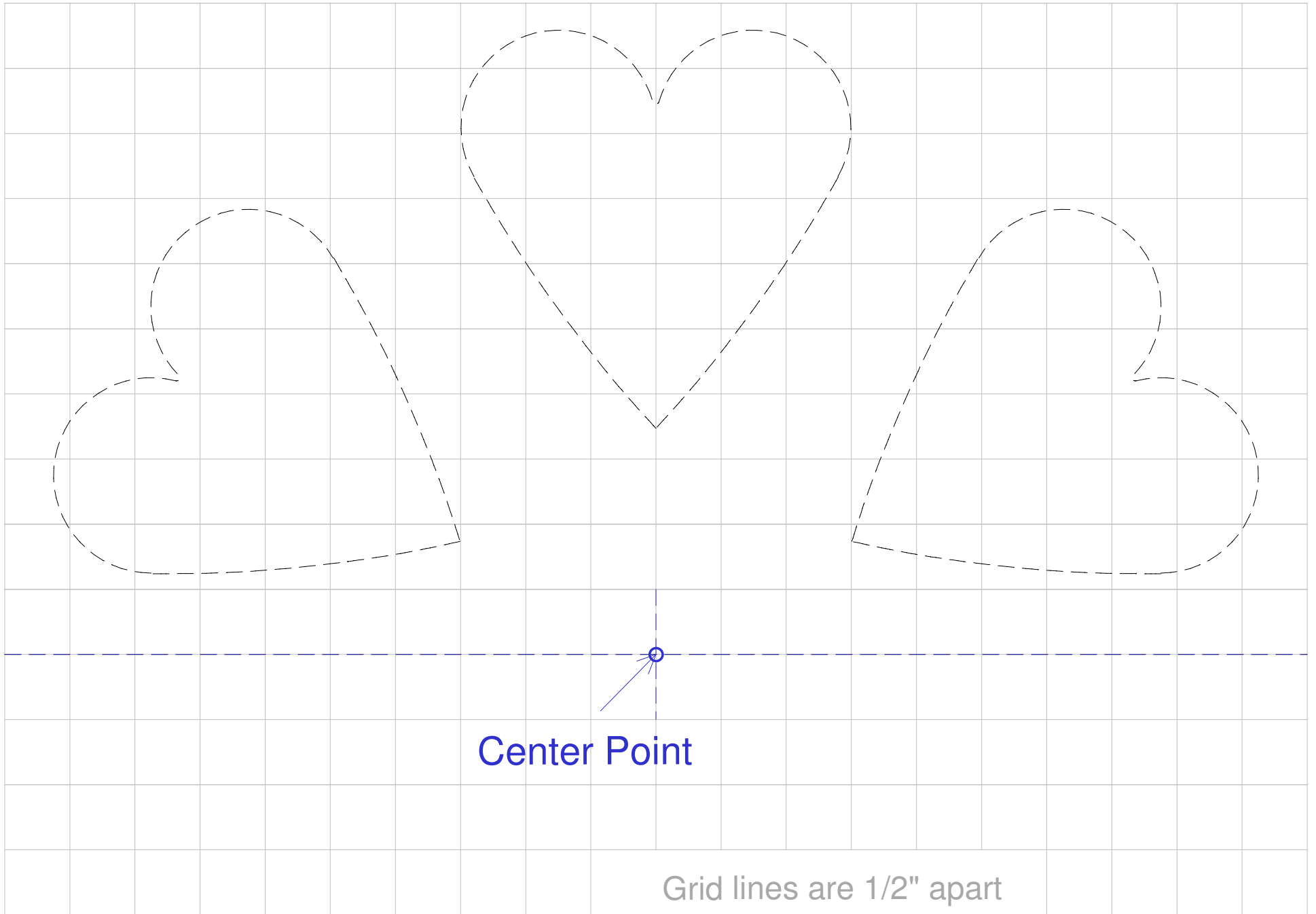

Apply weather proof glue to the mating edges of the boards and assemble as shown. Clamp them to a flat surface and secure them together with pocket hole screws.

It doesn't matter whether you cut out the hearts before gluing the pieces together or wait until they are glued. For your convenience, two heart patterns are provided.

If you have some spray on glue, you can glue the patterns to the wood and simply cut out along the outlines for the hearts. Otherwise, you can trace the outline onto the workpieces.

Note: you can always print out more patterns if you need to.

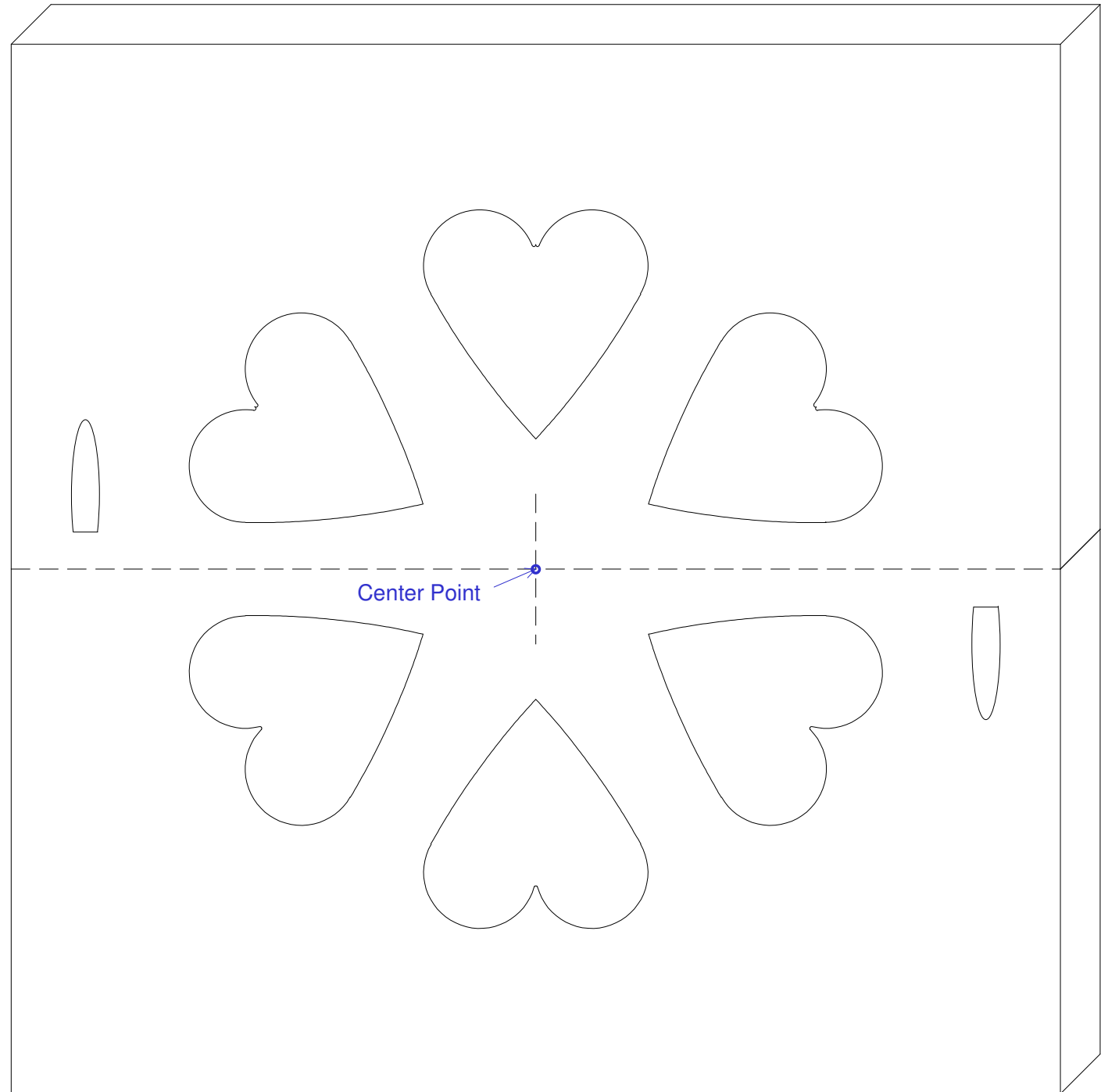

Heart Wheelbarrow - Heart Layout

Cut a 14" diameter circle
(7" radius) as shown. This
completes the heart wheel
center.

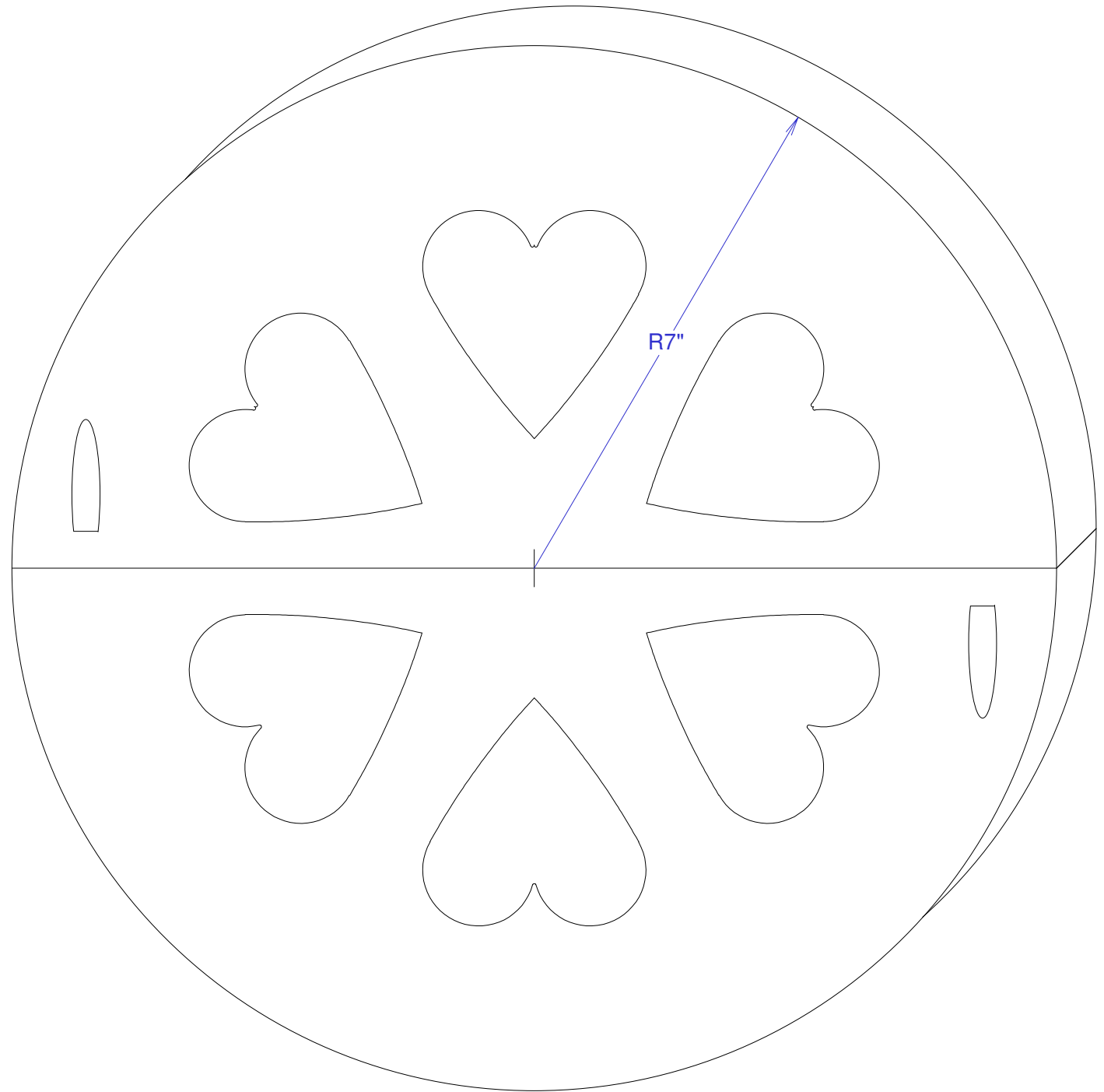

Rim Segment (Eight Required)

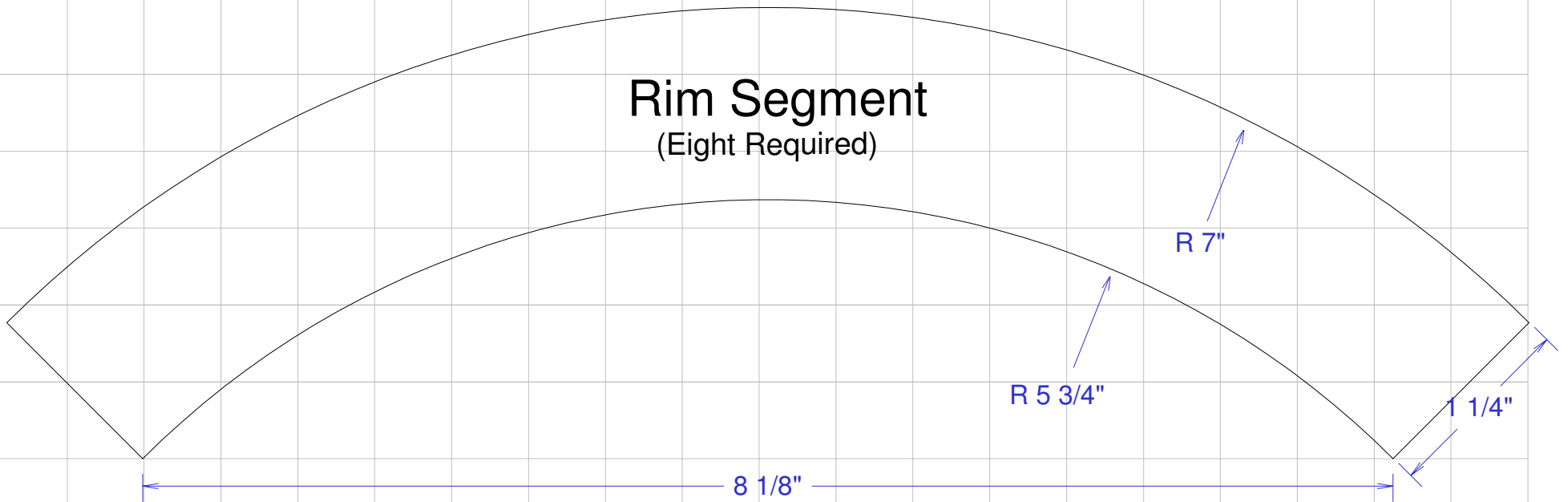

Drill and countersink three holes for #6 flathead screws,

Hub Rosette (Two Required)

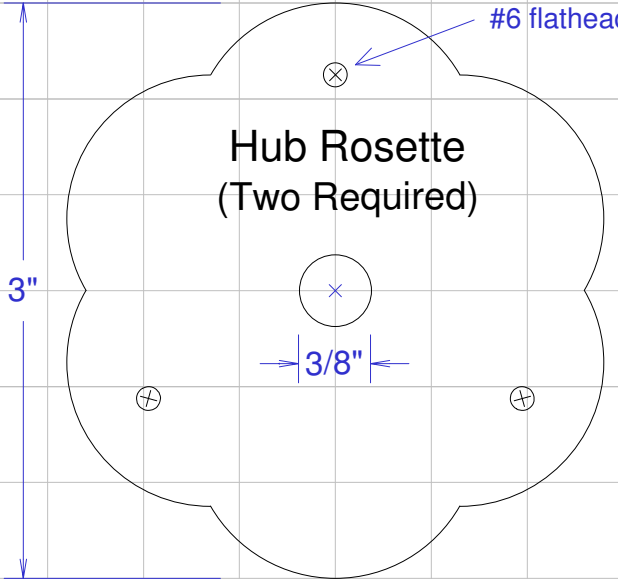

Hub Segment (Two Required)

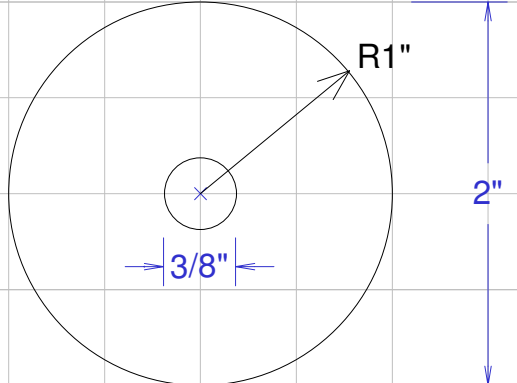

Grid lines are 1/2" apart

Apply some weatherproof glue to the mating surfaces of the four outer wheel trim pieces and assemble them as shown .
Secure them with finishing nails as shown.

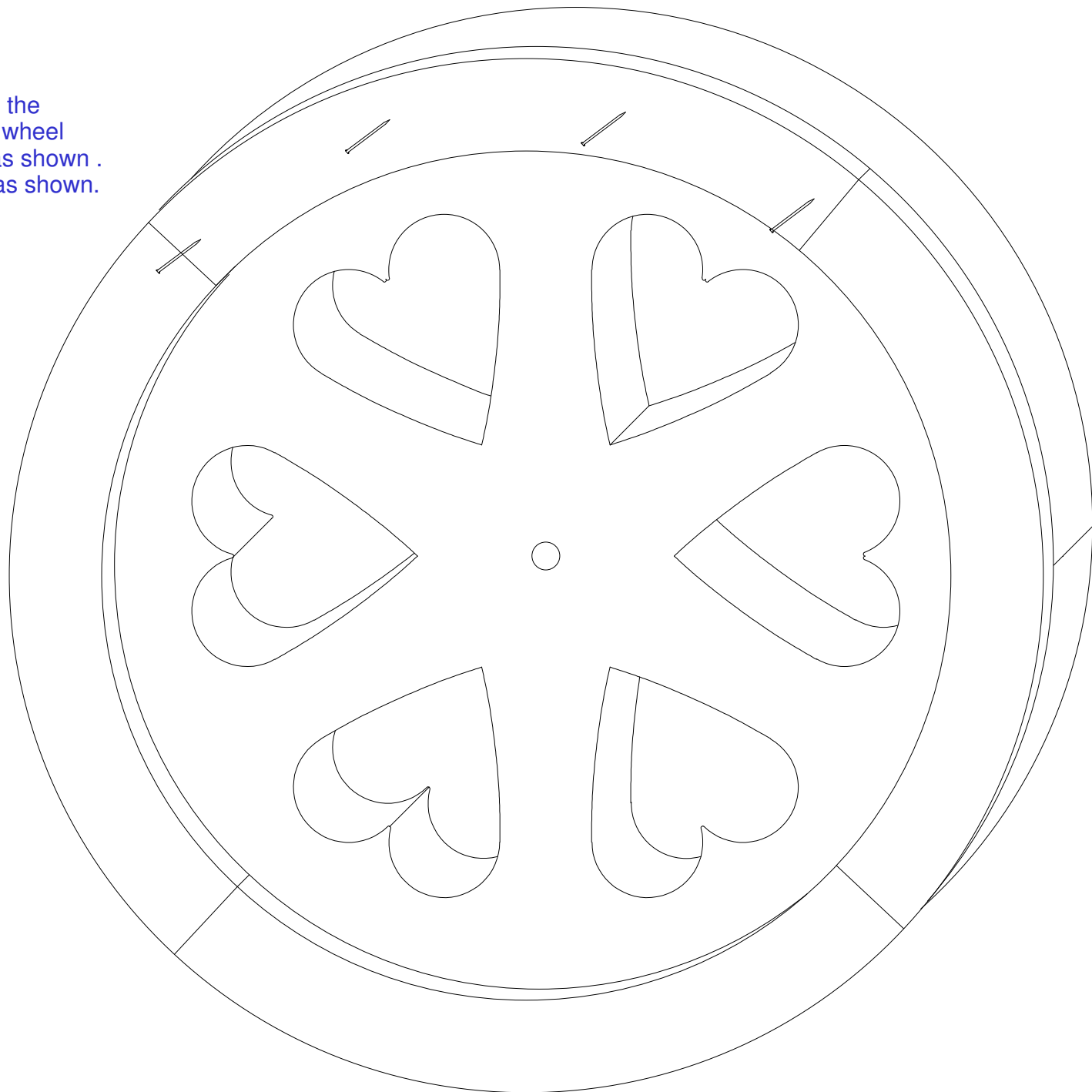

Heart Wheelbarrow - Attach Rim Segments

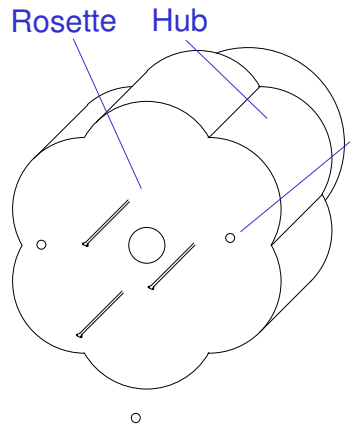

This is not the side with the countersunk holes . They go on the same side as the hub.

Apply some weatherproof glue to the mating surfaces of the Hub and Rosette. Position them as shown with the hub on the top surface of the rosette. Be sure the 3/8" axle holes are aligned. Secure them with 1 1/2" finishing nails as shown.

Apply some weatherproof glue to the bottom surface of the Rosette. Position it on the wheel center with the bottom of the hearts aligned with the rosette as indicated by the red line as shown. Be sure the 3/8" axle holes are aligned with the axle in the wheel center. Secure them with 1 1/2" long #6 brass screws.

Do the same for the other side but be sure the screws from the other side don't hit the screws from the first side.

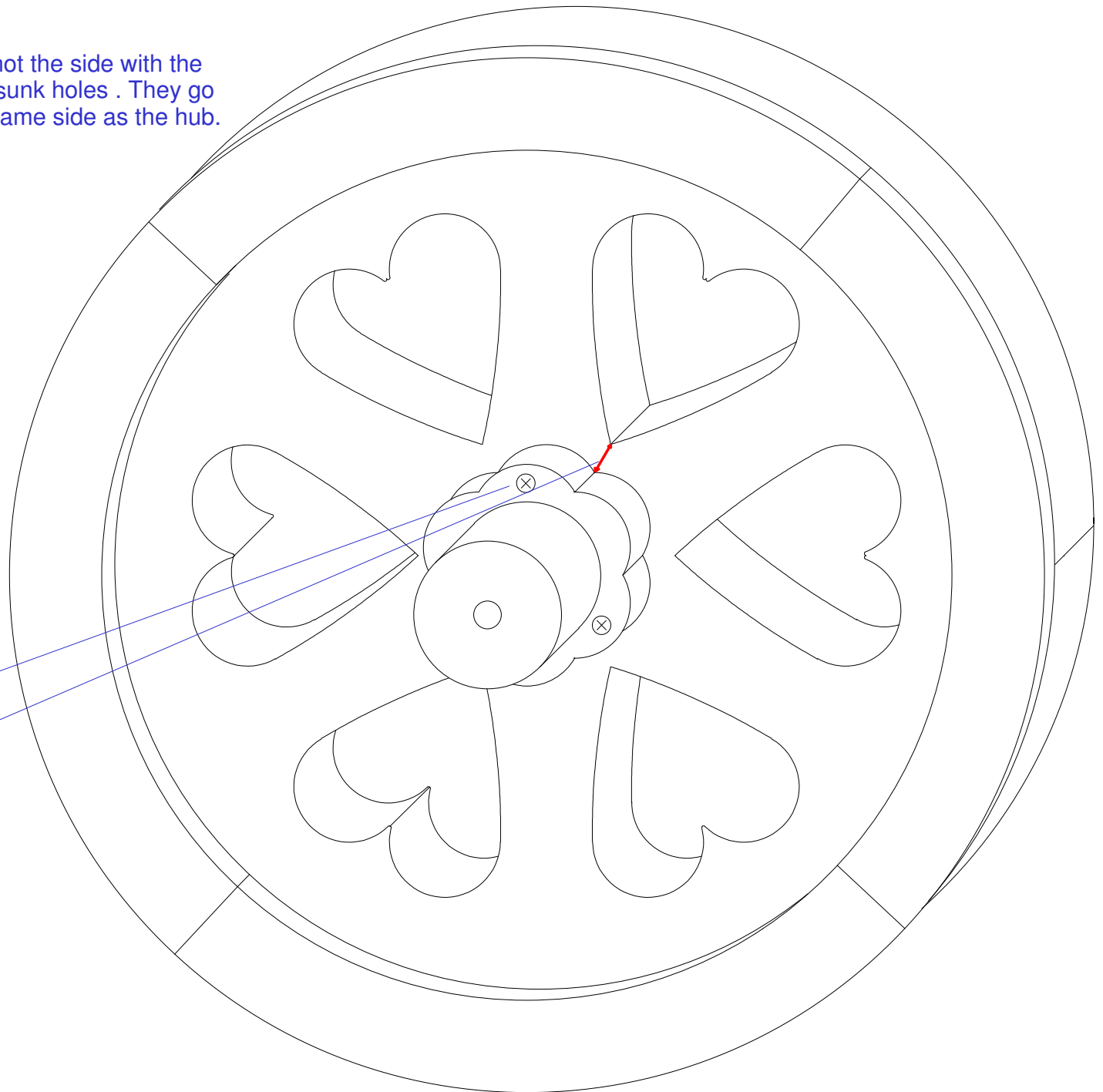

Heart Wheelbarrow - Attach Hub

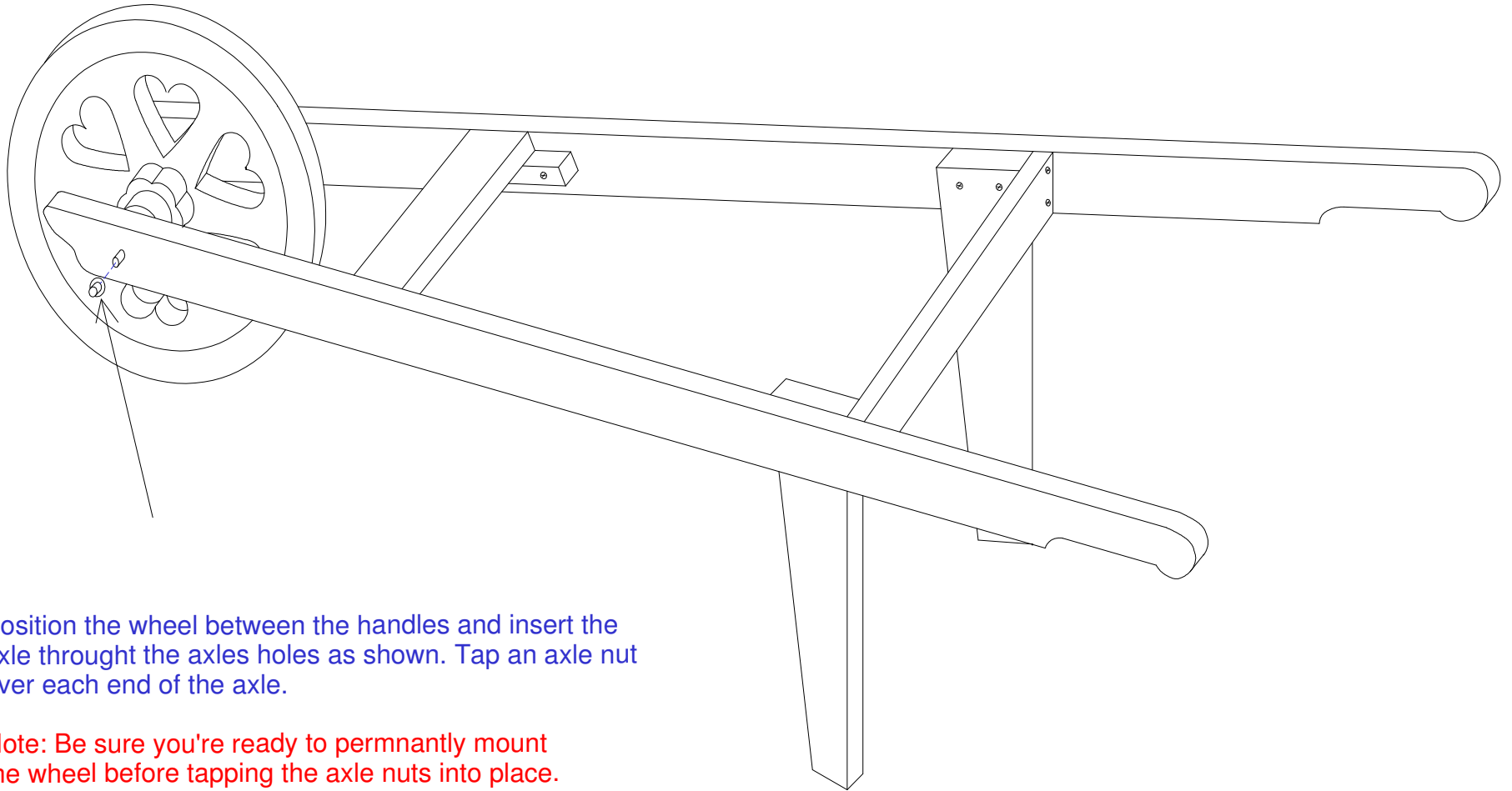

Position the wheel between the handles and insert the axle through the axle holes as shown. Tap an axle nut over each end of the axle.

Note: Be sure you're ready to permanently mount the wheel before tapping the axle nuts into place. It is extremely difficult to get axle nuts off after they have been pressed on.

The Tub Assembly

For your convenience, full size patterns of the curves and braces are provided on pages 18, 19, & 20. If you have a router, you need to round over the exposed edges (top and fronts of the sides, top of the top front piece, top of the back piece, and the rear of the three bottom pieces). Please refer to the isometric drawings on this page to see how they all go together.

First, assemble the side panels as shown in Figure 1. Use 1 1/4" coated exterior screws to attach the braces to the side panels. Note that the bottoms of the braces must be 3/4" above the bottom of the side panels. The corner braces provide strong corner joints and the side braces secure the rear of the top side pieces to the bottom side pieces. If you have a biscuit joiner or dowel jig, you can make the sides even stronger by joining them with dowels or biscuits in addition to the corner and side braces.

Next, attach the top and bottom front pieces and the back piece to one side panel as shown in Figure 2. Note the bottom front piece must be flush with the bottom of the side panels and the back piece must be 3/4" above the bottom of the side panels.

Next, assemble the bottom as shown in Figure 3 using 1 1/4" coated exterior screws to attach the bottom braces to the bottom pieces. Position the bottom as shown in Figure 4 and use finishing nails to attach the side panels to the bottom from the outer sides of the side panels.

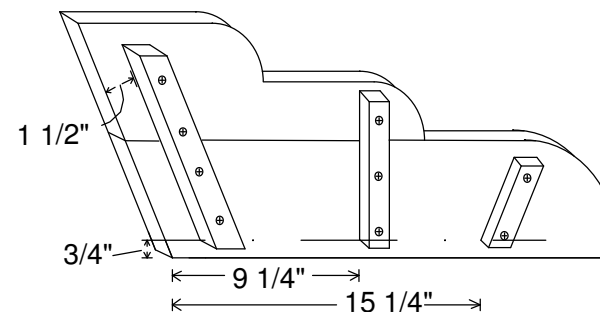

Figure 1

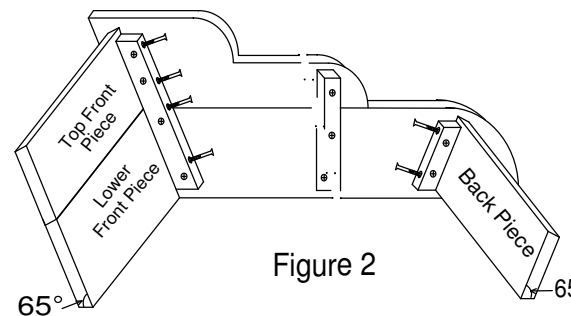

Figure 2

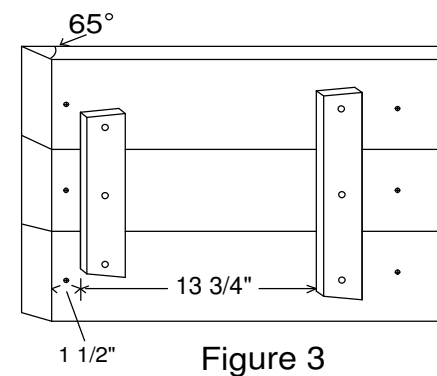

Figure 3

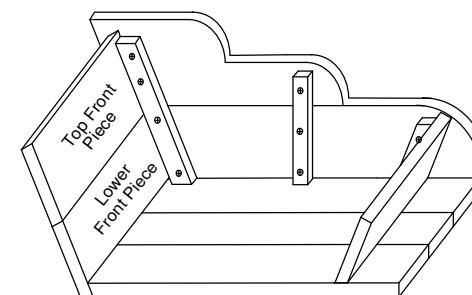
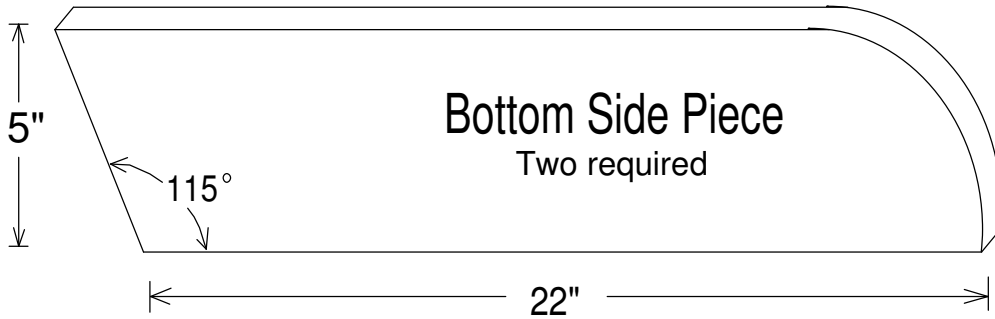
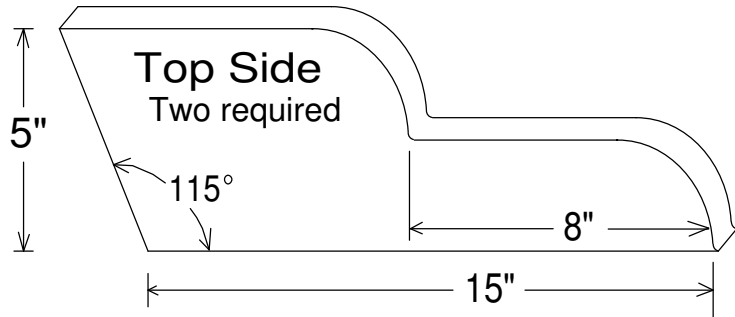
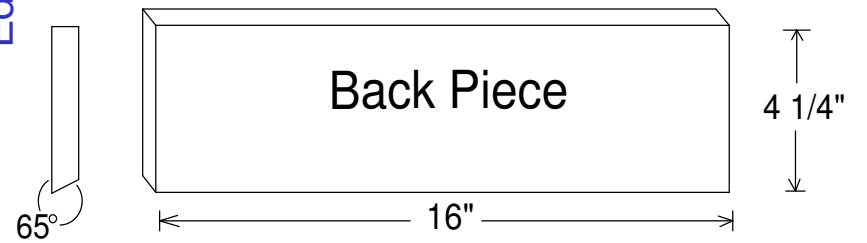
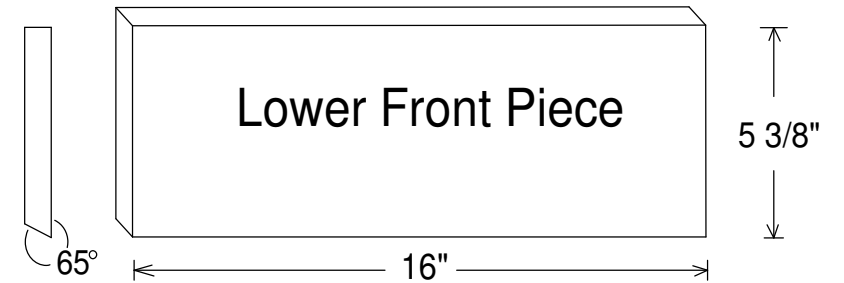
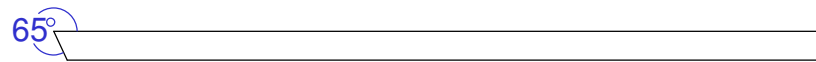
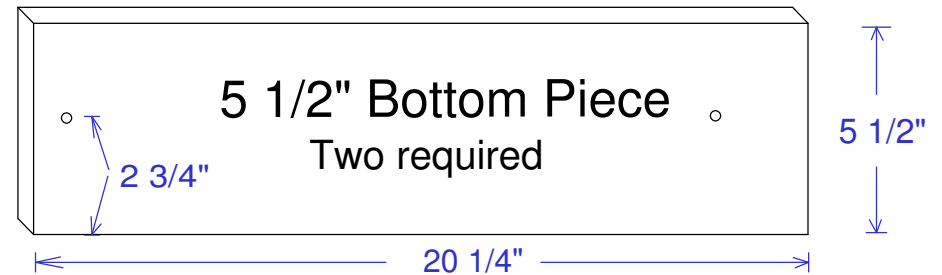
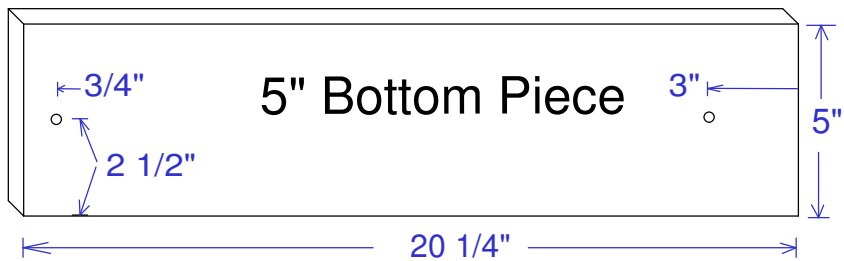

Figure 4



Edge View Front & Back Pieces





Edge View of Bottom Pieces

Front Corner Brace
Two Required

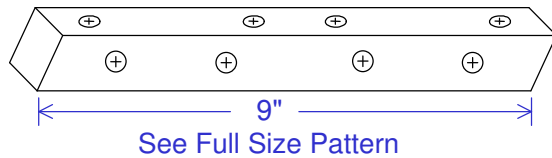

Side Brace
Two Required

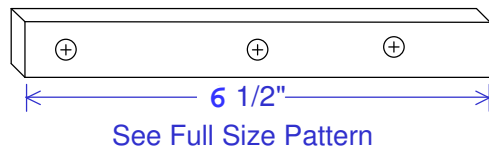

Rear Corner Brace
Two Required

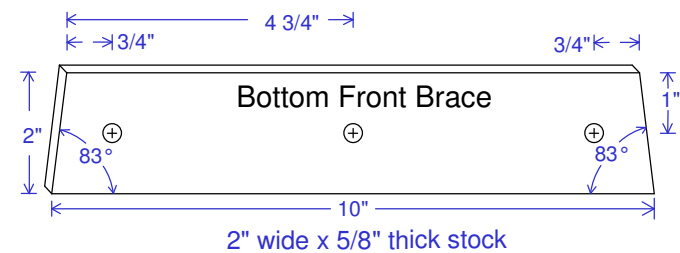
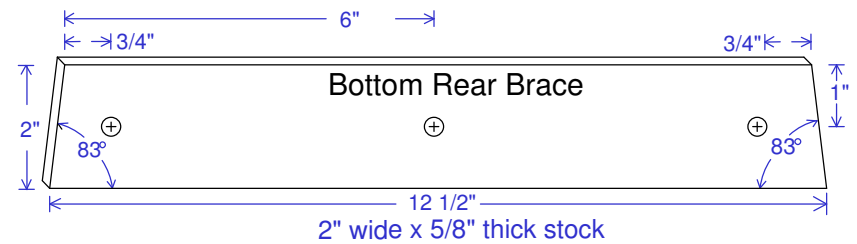
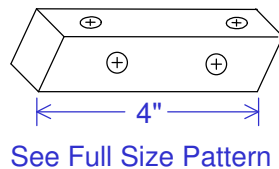

Top Side Scallops

Full Size Pattern

For the Bottom Side Piece

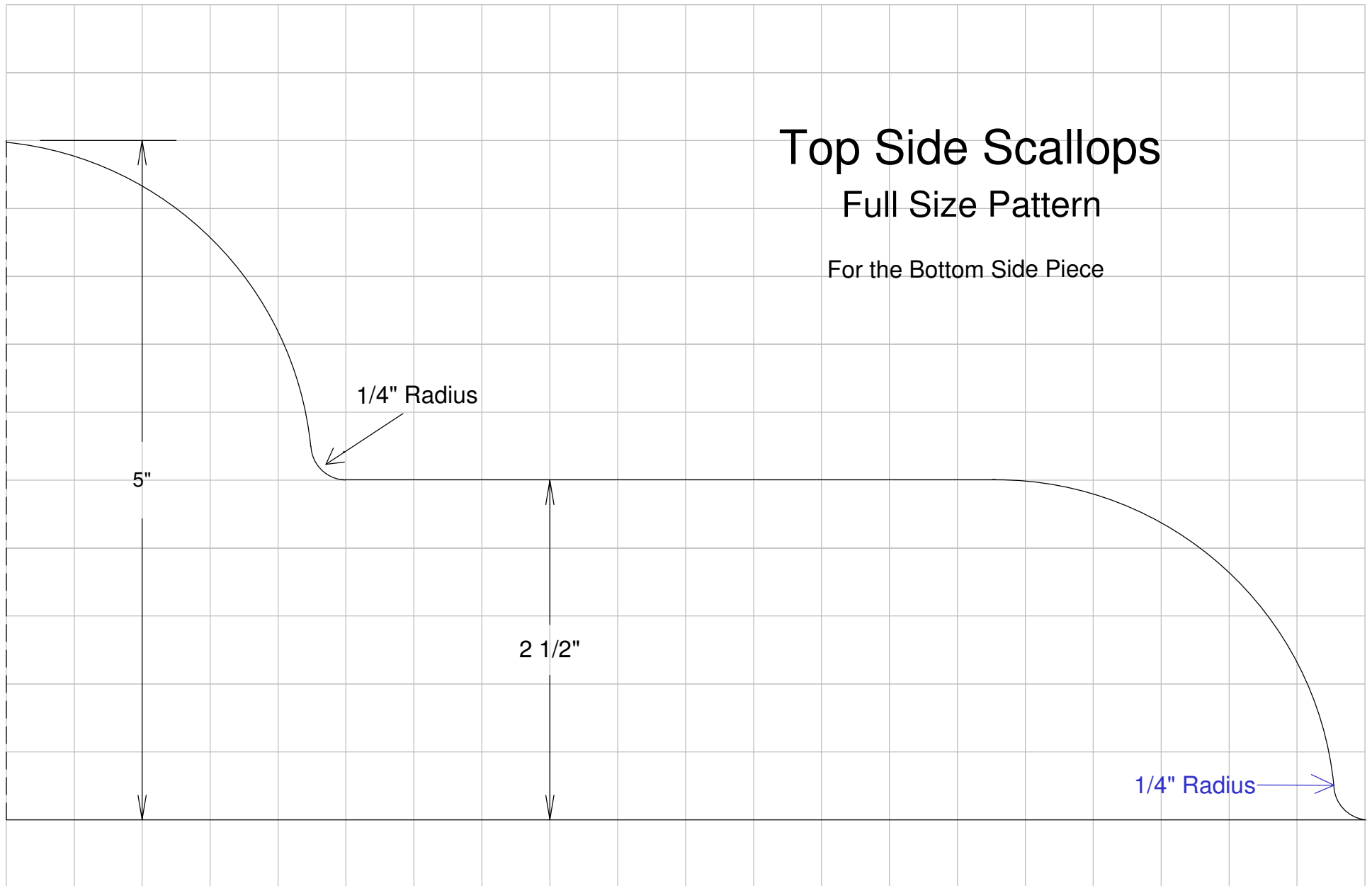

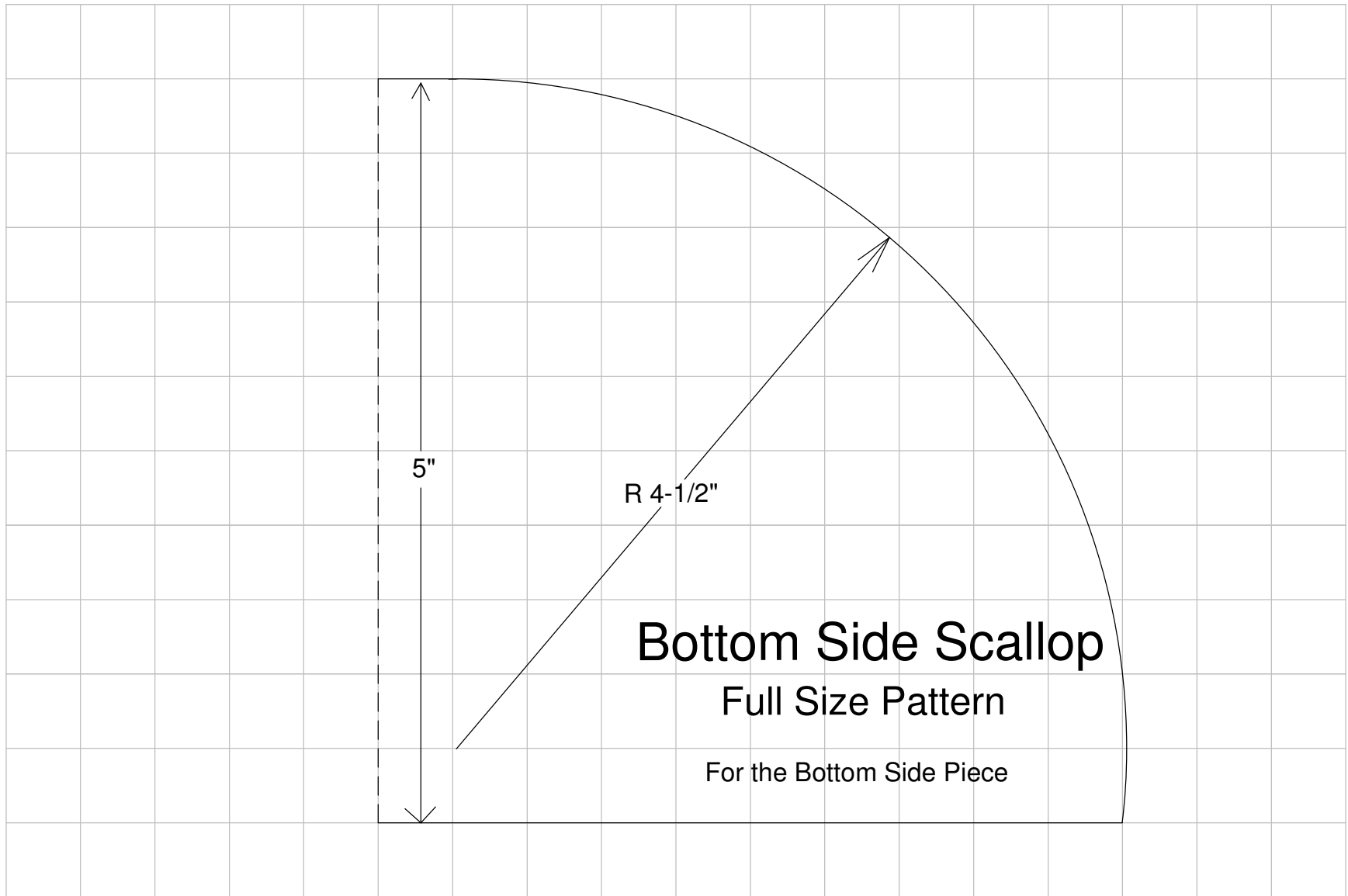

Grid lines are 1/2" apart

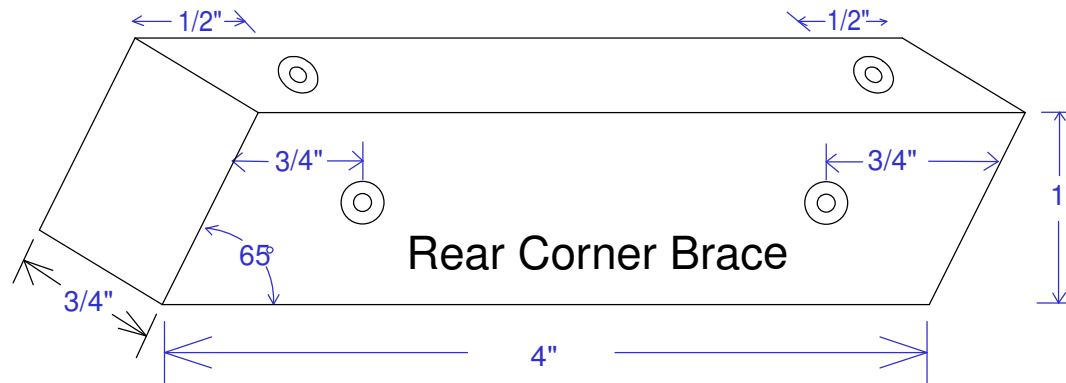
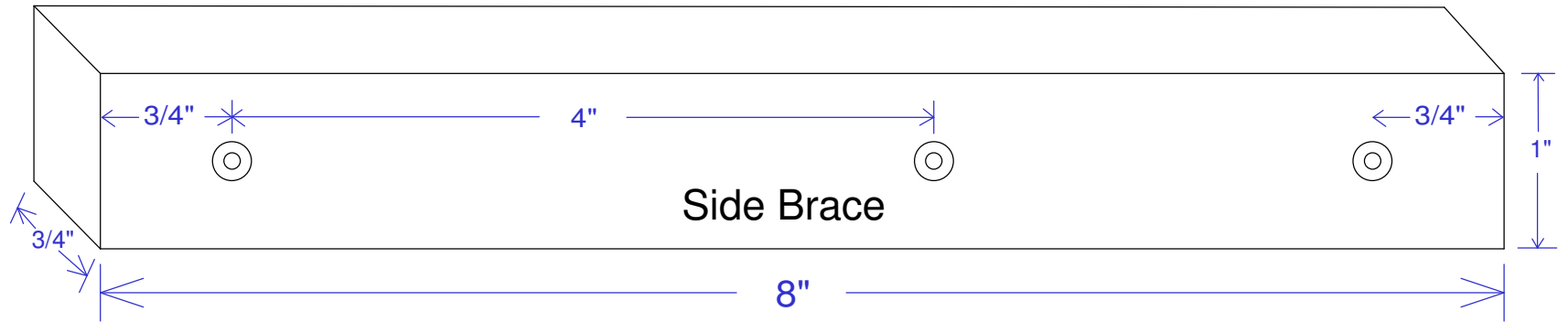
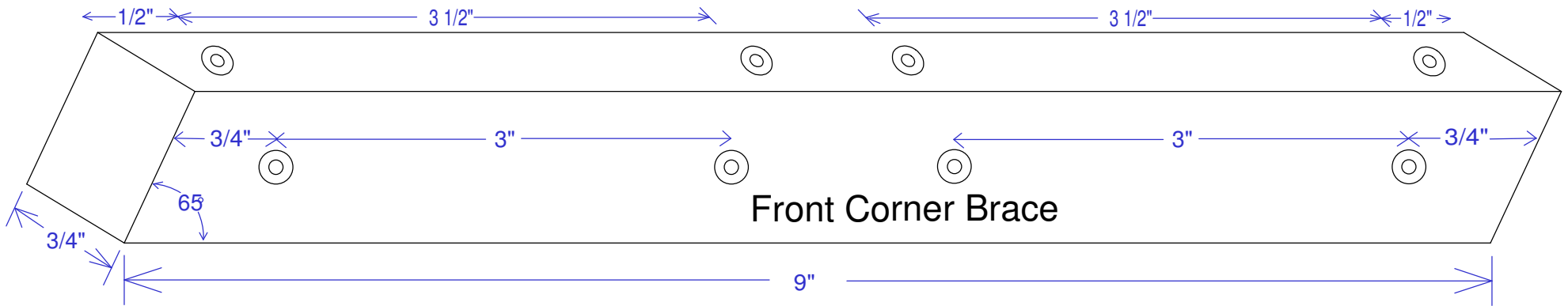

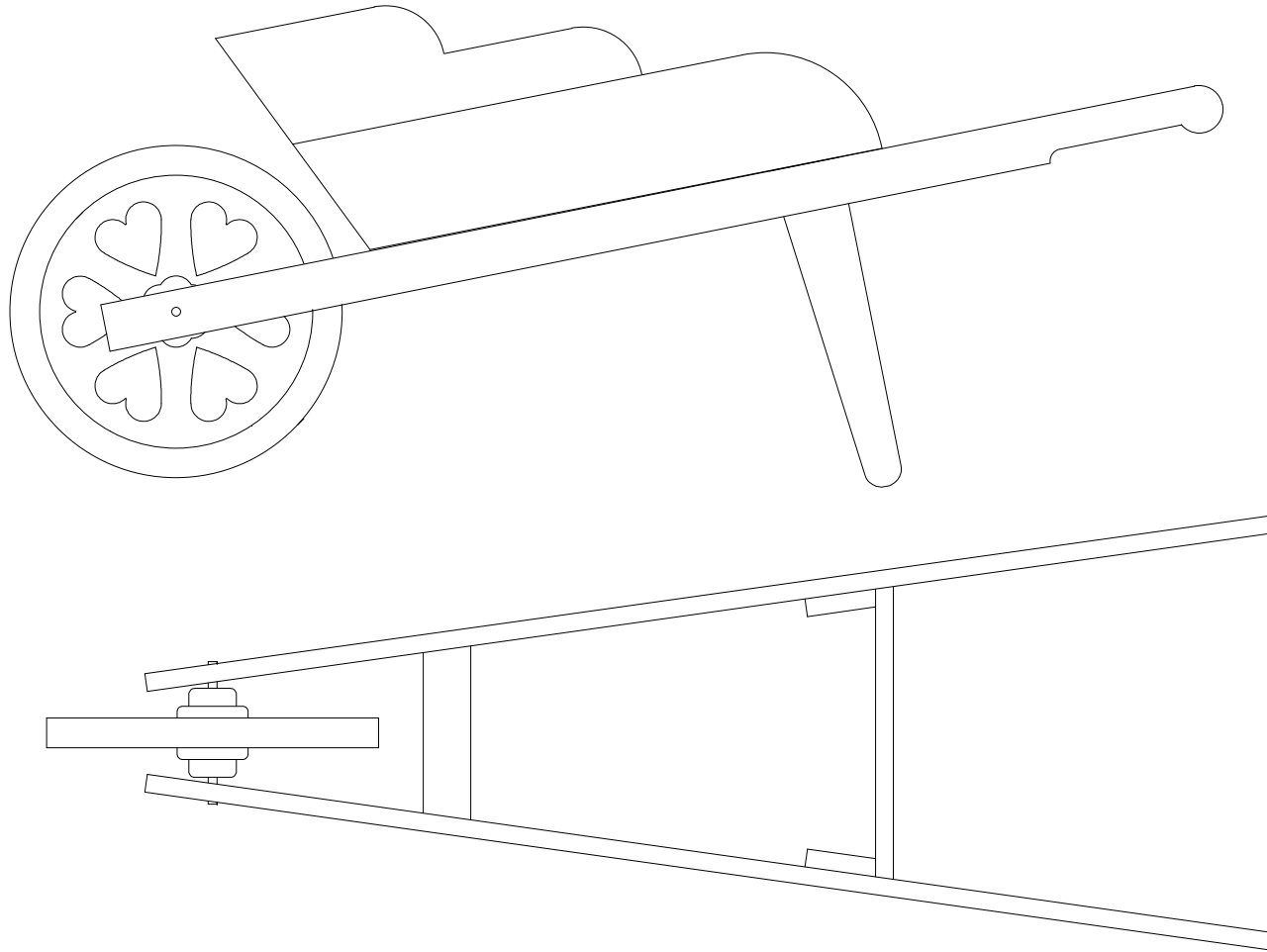

Position the finished tub assembly on the frame with the front of the tub flush with the front frame cross member and secure to the cross member with three 1 1/4" exterior screws. Secure the rear of the tub to the leg brace with three 1 1/4" exterior screws.

If the wheelbarrow is to be used as a flower planter, you need to drill a couple of 3/8" drain holes in the lowest part of the tub. This completes your wheel barrow planter.

Materials List

Qty	Size	Material
1	8' by 7 1/2" by 3/4"	Decay Resistant Wood
3	8' by 5 1/2" by 3/4"	Decay Resistant Wood
1	40" by 5 1/2" by 1/4"	Decay Resistant Wood

Except for the Rim Segments, everything is made from 3/4" thick material. This should be cedar, cypress, redwood, or other decay resistant wood.

The diagrams below provide a general layout for minimizing waste. Some of the smaller parts are not pictured and may be cut from the scrap.

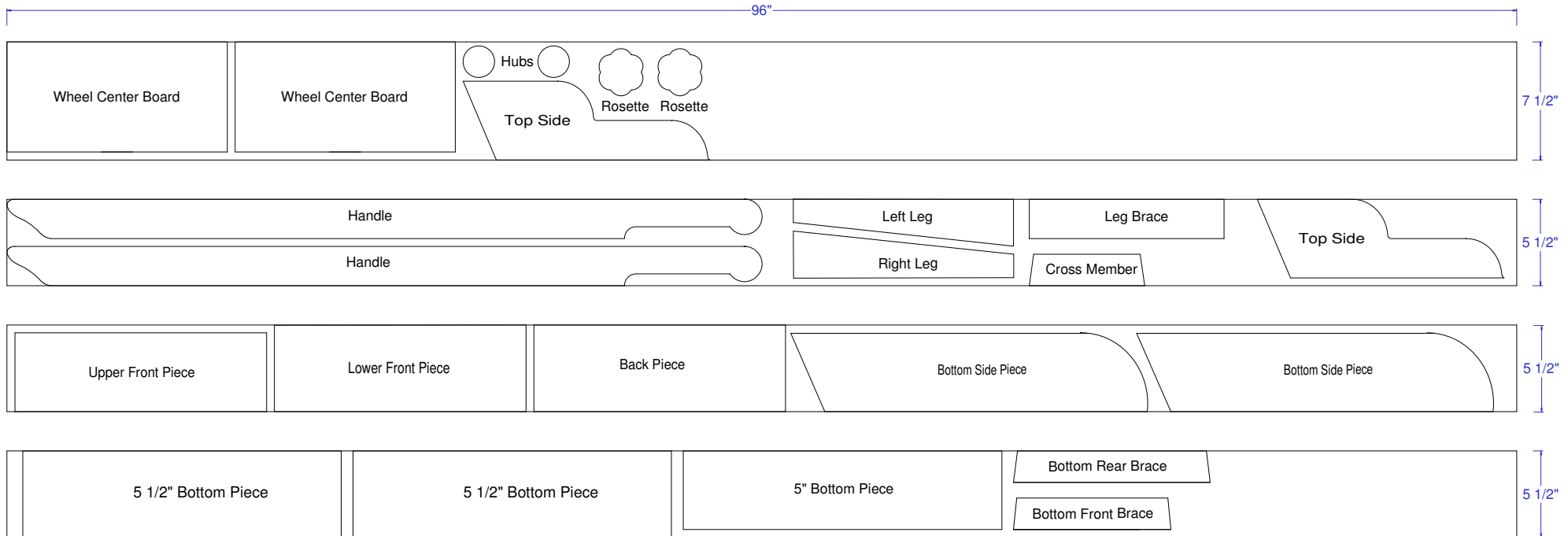

The eight Rim Segments are made of 1/4" thick material. If you cannot obtain 1/4" thick material of the same wood you're making the rest of the project from, you can use 1/4" thick exterior hardboard. This material is available in most home centers.

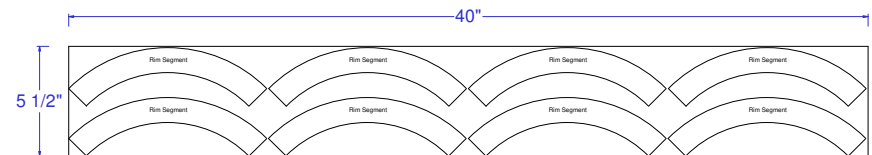

More Plans from: www.bobsplans.com



Router Table



Workbench



Dog House



Picnic Table



Octagon Table



6 Foot Bar



Corner Desk



Book Case



Mantel Clock



Redwood Planter



Wheelbarrow



Spoke Wheel



Panel Saw



Trellis



Wheelbarrow



Pocket Hole Jig



Tenoning Jig



Table Saw Sled



Drill Press Table